

# LAGUNA

## 1216

### Woodturning Lathe Operating Instructions

**Producer:**

Laguna Tools Inc  
744 Refuge Way, Suite 200  
Grand Prairie, Texas 75050  
USA  
Phone: +1 800-234-1976  
Website: [www.lagunatools.com](http://www.lagunatools.com)

**Distributor:**

IGM nástroje a stroje s.r.o.  
Ke Kopanině 560, 252 67, Tuchoměřice  
Czech Republic, EU  
Phone: +420 220 950 910  
E-mail: [sales@igmttools.com](mailto:sales@igmttools.com)  
Website: [www.igmttools.com](http://www.igmttools.com)

2022-02-17

151-1216 LAGUNA Woodturning Lathe Manual EN v1.3 A4cb



## EC DECLARATION OF CONFORMITY

We  
(Manufacturer)

Laguna Tools Inc.  
2072 Alton Parkway, Irvine, California 92606, USA

Declare that the product name: Wood Lathe

Model Name : REVO 18|36 Lathe, REVO 24|36 Lathe, REVO 12|16 Lathe, REVO 15|24

Conform with the essential safety requirements of the relevant European Directive:

- Machinery Directive 2006/42/EC
- Electromagnetic Compatibility Directive 2014/30/EU

The person who compile technical file established within the EU:

Name: IGM nástroje a stroje s.r.o.  
Address: Ke Kopanine 560, Tuchomerice , CZ-252 67  
Tel.: +420 220 950 910  
Email: [sales@igmtools.com](mailto:sales@igmtools.com)

Mounting and connecting instructions defined in catalogues and technical construction files must be respected by the user.

They are based on the following standards :

- EN ISO 12100:2010 Safety of Machinery - General principles for design / Risk Assessment and Risk reduction.
- EN 60204-1:2006+AC:2010 Safety of machinery – Electrical equipment of machines, part 1 : General requirements.
- EN 13849-1:2015 Safety of machinery – Safety – related parts of control systems Part 1: General principles for design
- EN 50370 -1:2005 Electromagnetic compatibility (EMC) – Product family standard for machine tools – Part 1: Emission.
- EN 50370 -2:2003 Electromagnetic compatibility (EMC) – Product family standard for machine tools – Part 2: Immunity.
- EN 61000-4-2: 2009 Electrostatic (ESD)
- EN 61000-4-4: 2012 Electrical fast transient/burst requirements (EFT/Burst)
- EN 61000-4-6: 2014 Immunity to conducted disturbances, induced by radio-frequency fields (CS)

Responsible for the documentation: Head Product Management, Laguna Tools Inc.

Name : Torben Helshoj

Responsibility : President

Authorized Signature

Date : Oct. 15, 2021

Place : Laguna Tools Inc.

2072 Alton Parkway, Irvine, California 92606, USA

Telephone: +1 800 234-1976

Fax: +1 949 474-0150



# EN - English

## Operating instructions (Translation of original)

Dear Customer,

many thanks for the confidence you have shown in us with the purchase of your new Laguna Tools machine. This manual has been prepared for the owner and operators of an **IGM LAGUNA Revo 1216 Woodturning Lathe** to promote safety during installation, operation and maintenance procedures. Please read and understand the information contained in these operating instructions and the accompanying documents. To obtain maximum life and efficiency from your machine, and to use the machine safely, read this manual thoroughly and follow instructions carefully.

We wish you many work and personal pleasures when working with the Laguna Tools machine.

## Table of Contents

### 1. Declaration of Conformity

### 2. Warranty

### 3. Safety

Authorized Use  
General Safety Notes  
Hazards  
Grounding Instructions  
Woodturning Lathe

### 4. Machine Specification

External Description  
Internal Description  
Inventory

### 5. Transport and Setup

Receiving  
Machine Placement  
Unpacking

### 6. Setting and Adjustment

Installing Rubber Levelling Pads  
Installing/Removing Faceplate & Hand Wheel  
Installing/Removing Drive Centre and Live Centre  
Removing Drive Centre  
Removing Live Centre  
Changing Speed Range

### 7. Machine Operation

First Use  
Workpiece Clamping  
Turning on the Lathe

### 8. Accessories

### 9. Maintenance

---

#### 1. Declaration of Conformity

We declare that this product is in compliance with the directive and the standard mentioned on the previous page of this manual.

#### 2. Warranty

The company IGM Tools & Machinery s.r.o. always strives to deliver a product of high quality and efficiency.  
The application of the warranty is governed by the valid Business Conditions and the Warranty Conditions of the company IGM Tools & Machinery s.r.o.

#### 3. Safety

##### 3.1 Authorized Use

Lathe is designed for sanding wood and wooden products only.

Sanding of other materials is not permitted.

The required minimum age must be observed.

The machine must only be used in a technically perfect condition.

In addition to the operating instructions, also read the safety requirements and your country's applicable regulations.

You should observe the generally recognized technical rules and safety requirements concerning the operation of woodworking and metalworking machines.

Neither the manufacturer nor the supplier is liable for damage resulting from unauthorized use of the machine.

Responsibility is transferred exclusively to the operator.

##### 3.2 General Safety Notes

Woodworking machines can be dangerous if not used properly. Read and understand the entire operating manual before attempting assembly or operation. Protect this operating manual from dirt and humidity, and pass it over to the new owner if you part with the machine.

No changes to the machine may be made.

Tighten all loose parts and locks before operating.

Daily inspect the function and existence of the safety appliances before you start the machine. Correct all defects or damaged safety appliances immediately. The machine must only be used in a technically perfect condition.

Make all machine adjustments or maintenance with the machine unplugged from the power source.

Protect long hair with a cap or hair net. Remove all loose clothing, rings, watches and other jewellery. Wear safety shoes; never wear leisure shoes or sandals. Do not wear gloves while operating this machine!

Follow personal protection guidelines.

Always wear safety goggles. Always wear ear protection. Tools are sharp and can lead to serious injuries, handle them with care.

Install the machine so that there is sufficient space for safe operation and workpiece handling.

The machine must be bolted on firm and levelled surface and must be properly lighted.

Only process workpieces without defects.

Keep pulley cover closed!

Always use tool rest when turning.

Always wear a protective mask in a dusty environment. Keep work area well lighted.

Make sure the machine stands on a board.

Make sure that the power cord does not impede work. Keep work area clean. Work only with well sharpened and clean tools.

Never reach into the machine while it is operating or running down.

Stay alert! Give your work undivided attention. Use common sense. Do not operate the machine under the influence of drugs, alcohol or any medication.

Keep children and visitors a safe distance from the work area. Never leave a running machine unattended. Before you leave the workplace switch off the machine.

Do not use the machine in a damp environment and do not expose it to rain.

Focus on the position of your fingers and other parts of your body when working. Do not start the machine without safety appliances.

Machine only stock which rests securely on the table.

Do not remove chips and workpiece parts until the machine is at a standstill.

Clamp the workpiece only when the machine is switched off. Rotate the workpiece by hand before starting the machine. Rough out the workpiece before installing it on the faceplate.

Do not stand on the machine.

Use a suitable power cord that can handle the machine's power input.

Connection and repair work on the electrical installation may be carried out by a qualified electrician only.

Have a damaged or worn power cord replaced immediately.

Make all machine adjustments or maintenance with the machine unplugged from the power source.

### 3.3 Hazards

When using the machine according to regulations some remaining hazards may still exist.

Thrown workpieces and workpiece parts can lead to injury.

Only process selected woods without defects.

Dust and noise can be health hazards.

Be sure to wear safety goggles, ear protection and dust mask.

Do not use damaged or worn power cord.

### 3.4 Grounding Instructions

Connection cord:

In case of a defect or malfunction, grounding provides a path of least resistance to electric current, reducing the risk of electric shock. The machine is supplied with connection cord with a guard wire and euro plug. The plug must only be connected to an appropriate outlet in accordance with all local codes and regulations.

- Do not modify the plug, if it does not fit into the socket. Contact a qualified electrician and have the appropriate socket installed.
- Improper connection may result in a risk of electric shock. Ground wire is an insulated wire with a green surface with/without yellow stripes. If the cord or plug needs to be repaired, contact a qualified electrician.
- Damaged cords should be repaired immediately and only by a qualified electrician.
- Use only three-wire cables with a euro plug and an appropriate socket.

### 3.5 Woodturning Lathe

Woodturning lathes are typically used to shape wood into cylindrical profiles. Objects made on a wood lathe include items such as furniture legs, lamp posts, baseball bats, bowls and other ornamental forms. Wood lathe tooling consists of fixturing and securing devices for the workpiece, a moveable toolrest and hand-held cutting tools in the form of long handled gouges, skewers, scrapers and parting tools. Specialty tooling is also available for internal shaping and surface development.

### Electrical supply conditions - info for electricians

Voltage: Steady state voltage: 0,9 to 1,1 of nominal voltage.

Frequency: 0,99 to 1,01 of nominal frequency continuously; 0,98 to 1,02 short time.

Harmonics: Harmonic distortion not exceeding 10 % of the total r.m.s. voltage between live conductors for the sum of the 2nd through to the 5th harmonic. An additional 2 % of the total r.m.s voltage between

live conductors for the sum of the 6th through to the 30th harmonic is permissible.

Voltage unbalance: Neither the voltage of the negative sequence component nor the voltage of the zero sequence component in three-phase supplies exceeding 2 % of the positive sequence component.

Voltage interruption: Supply interrupted or at zero voltage for not more than 3ms at any random time in the supply cycle with more than 1s between successive interruptions.

Voltage dips: Voltage dips not exceeding 20 % of the peak voltage of the supply for more than one cycle with more than 1s between successive dips.

### Physical environment and operating conditions

Ambient air temperature: between 5° C to 40° C

Humidity: The relative humidity does not exceed 50 % at a maximum temperature of 40° C.

Altitude: Up to 1000 m MSL.

Transportation and storage: Within a range of -25°C to 55° C and for short periods not exceeding 24 hours up to 70° C.

### Locking the lathe

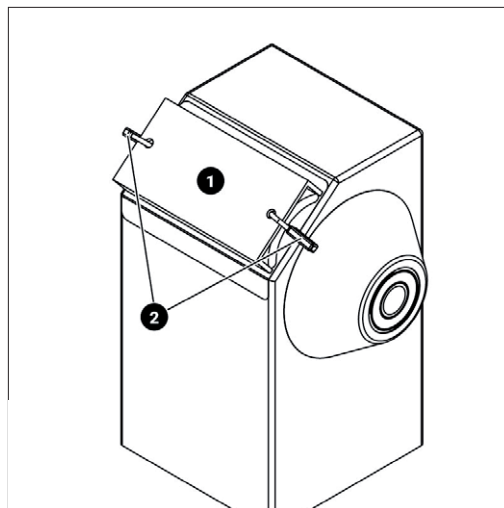

Fig. 1

Fig. 1: Method of locking Laguna Revo lathe. (1) Constructed 3 side box with padlock holes. (2) Padlocks.

It is strongly recommended that the lathe is never left unattended in the unlocked condition. To lock the machine it is recommended that a cover (not supplied) is constructed.

## 4. Machine Specification

### Motor specification

Power: 230V / 50 Hz / 1 phase  
Power output: 0,75 kW, S1  
(S1 - Permanent load)

Current at maximum load 2,5 A  
Recommended circuit breaker 16 A, tripping rating C (16/1/C)

### Dimensions

Package dimensions (LxWxH): 920 mm x 380 mm x 520 mm  
Package weight: 61 kg

Length x width x height: 750 mm x 226 mm x 442 mm  
Weight: 56,3 kg  
Floor to bed height (no pads): 170 mm  
Floor to Spindle Centre height (no pads): 328,75 mm  
Bed length: 746,8 mm  
Toolrest length: 203,2 mm  
Toolrest post diameter: 25,4 mm  
Faceplate diameter: 76,2 mm

### Lathe Specification

High Speed Range: 950 - 3500 RPM  
Mid Speed Range: 450 - 1750 RPM  
Low Speed Range: 100 - 525 RPM  
Distance between Centres: 390 mm  
Swing over Bed: 310 mm  
Swing over Banjo: 241 mm  
Spindle Bore: 9,5 mm  
Spindle / Tailstock Taper: MK2 / MK2  
Spindle Thread: M33 x 3,5 mm

Front Bearing: 6006LLU  
 Rear Bearing: 6005LLU  
 Indexing: 24 positions with lock  
 Inverter: PWM  
 Drive belt: 6 Groove Poly-V belt  
 Tailstock quill travel: 63 mm

**Materials**

Bed: Cast Iron  
 Head / Tailstock: Cast Iron  
 Legs / Base (optional): Steel  
 Toolrest: 1045 Steel  
 Toolrest Contact Rod: 6 mm Hardened 1045 Steel  
 Banjo: Cast Iron

<b>LAGUNA CE</b>			
<b>Laguna REVO 12   16 Lathe</b>			
Model	MLAREVO1216EVS		
Power	1~230V 50Hz 2.5A P2=0.75kw S1		
Specification	 $n_0=0 - 3500 / \text{min}$ SCCR=6k A $M33 \times 3.5 / \text{MT-2} / \phi 10.5 \text{mm}$		
Article No.	Weight	56.3kg	
Series No.	Year		
<b>LAGUNA TOOLS</b> 2072 Alton Parkway, Irvine, CA 92606 <a href="http://www.lagunatools.com">www.lagunatools.com</a>			

Fig. 2

**Laguna Revo 1216 Woodturning Lathe dimensions**

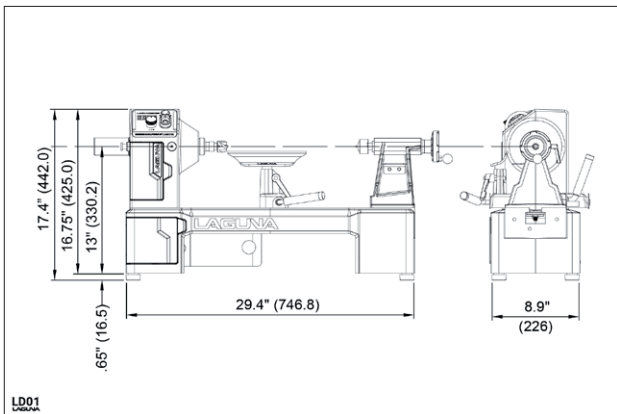

Fig. 3

**Revo 1216 Expansion Set 254 mm**

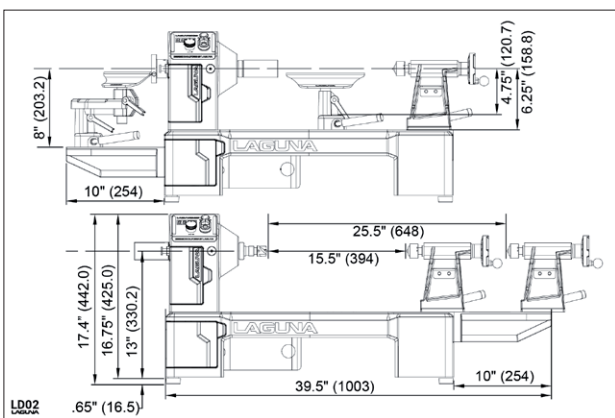

Fig. 4

**Revo 1216 Adjustable Stand**

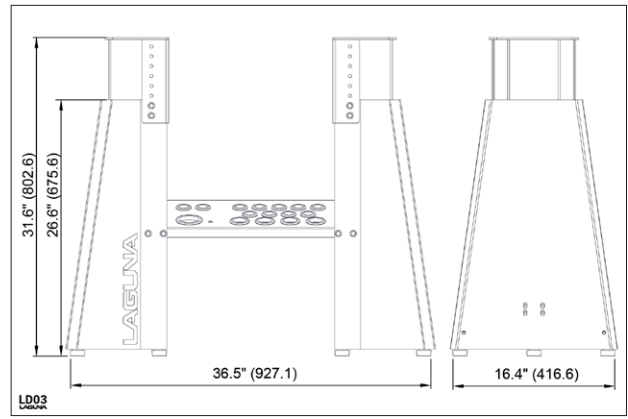

Fig. 5

**Mobility Kit for 1412-14BX-1216**

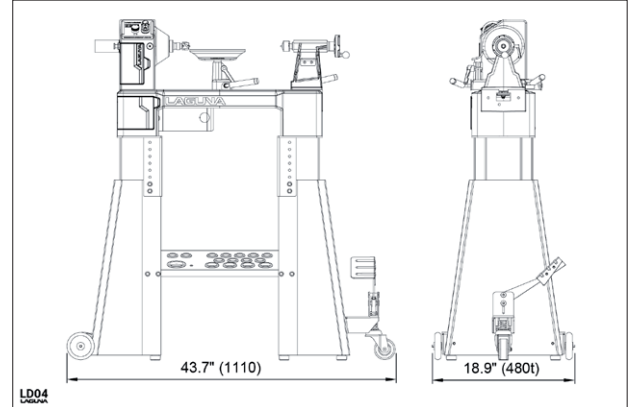

Fig. 6

**4.1 External Description**

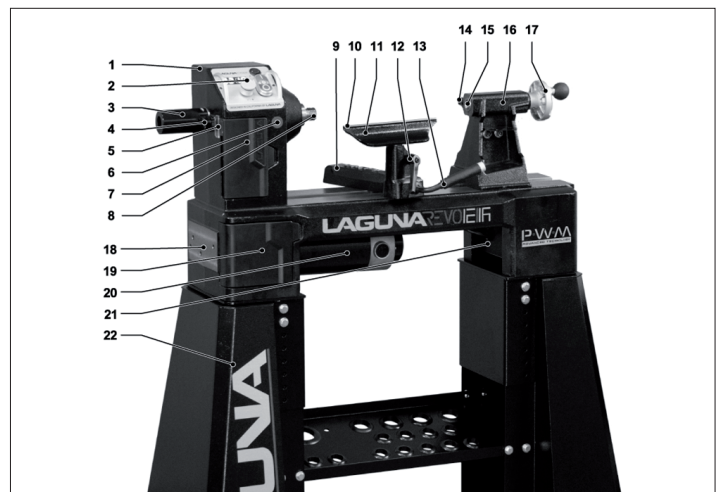

Fig. 7

- 1 Headstock
- 2 Control Panel
- 3 Spindle Hand Brake
- 4 Indexing Lock
- 5 Indexing View Port
- 6 Spindle Lock
- 7 Upper Belt Door
- 8 Spindle
- 9 Banjo
- 10 Hardened Steel Leading Edge
- 11 Toolrest
- 12 Toolrest Lock
- 13 Banjo Lock
- 14 Quill Lock
- 15 Quill
- 16 Tailstock
- 17 Hand wheel
- 18 Expansion Mount
- 19 Lower Belt Door
- 20 Motor
- 21 Controller

## 4.2 Internal Description

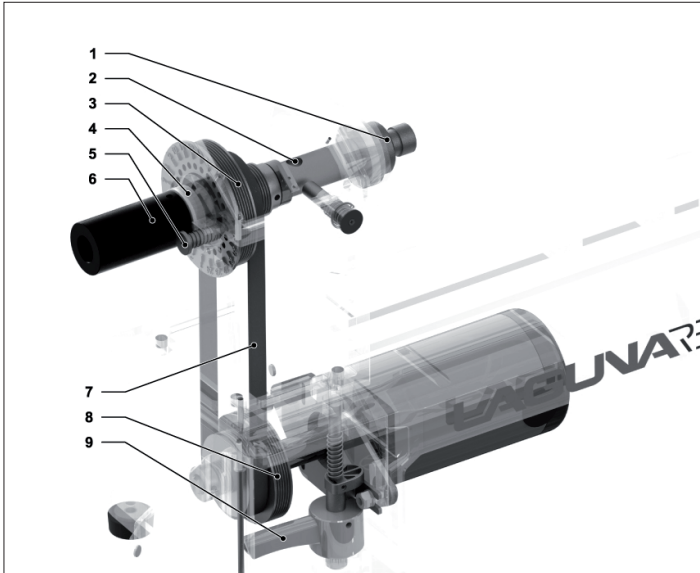

Fig. 8

- 1 Front Bearing (Press Fit)
- 2 Spindle Lock Boring
- 3 Upper Belt Pulley Steps
- 4 Rear Bearing (Floating)
- 5 Indexing Lock
- 6 Spindle Hand Brake
- 7 Belt
- 8 Lower Belt Pulley Steps
- 9 Belt Tension Lock

## 4.3 Inventory

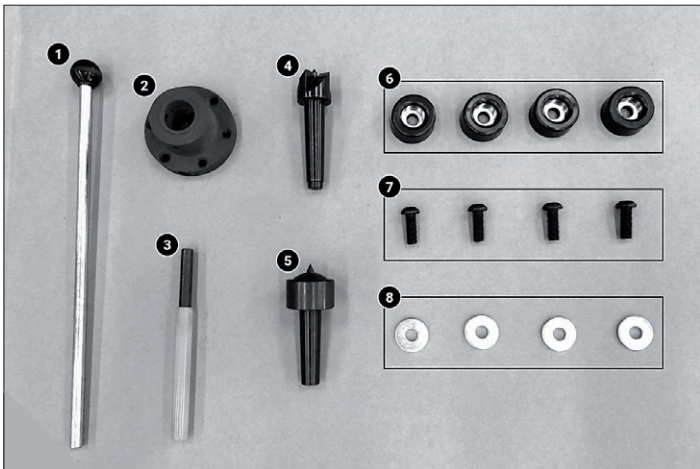

Fig. 9

1. Centre Knockout Rod PLAREVO1216-1103A. Used to release the headstock centres.
2. Faceplate PLAREVO1216-104A. 76 mm (3") faceplate used to fasten workpiece.
3. Faceplate Wrench PLAREVO1836-1136. To release faceplate from spindle threading.
4. Drive Centre PLAREVO1836-124A. Used in the headstock to turn a workpiece. No bearing.
5. Live Centre PLAREVO1216-168. Used in the tailstock to keep the workpiece rotating. Has a bearing.
6. 4x Rubber Foot PLAREVO1216-199. To limit vibrations - Remove if using a stand.
7. 4x Screw for Rubber Foot PLAREVO1216-1100.
8. 4x Flat Washer PLAREVO1216-198.

## 5. Transport and Setup

### 5.1 Receiving

It is likely that your machine will be delivered by a third party. Before unpacking, be sure to inspect the packaging and shipping documents supplied by the driver. Ensure that there is no visible damage to the shipment. If any damage has occurred because of shipment, note the

damage on the bill of lading or refuse the shipment. Immediately call the dealer store where the machine was purchased.

1. Never accept a shipment that is damaged or partial without notifying the shipping company and the purchasing store.

### 5.2 Machine Placement

Prior to removing the machine from the packaging, decide the operating location of the machine. The dimensions and floor space can be found here: Dimensions.

1. There should be sufficient area at the front of the machine to allow you to work on it comfortably.
2. There should be sufficient area at the back of the machine to allow access for adjustments and maintenance to be conducted.
3. The better the lighting the more accurately and safely you will be able to work.
4. You should select a solid flat floor, preferably one made of concrete or similar material.
5. Locate the machine close to a power source and dust collection.

### 5.3 Unpacking

Once in place, carefully unpack and remove all components. Unpacking guidelines:

1. Do not cut deep into a box with a blade as it could scratch the paint. Only cut deep enough to cut the tape or use a dull edge.
2. Organize the hardware and setup tools needed prior to proceeding with setup.

## 6. Setting and Adjustment

### Setting

**WARNING!** Never perform any setup, maintenance or adjustments with the machine connected to the power source!

**WARNING!** If you have any doubt about the described procedure, seek professional assistance. Do not attempt any procedure that you feel is unsafe, or that you do not have the physical capability of achieving.

**WARNING!** When removing packaging banding, extreme caution must be used as the banding will spring when cut.

**CAUTION!** The machine is heavy. Ensure that you have enough people to do the job safely.

**TIP** There may be sawdust in or around your new machine as a result of thorough testing.

**TIP** Numbers used to describe images are not the same as numbers used to describe the individual parts in the Parts Section. This is done solely to help with assembly and give better instructions to those receiving the machine new. When ordering replacement parts, please only consult the part numbers and reference images in the Parts Section.

The machine comes as assembled as possible without impacting shipping costs. With this, there will always be some setup procedures and adjustments that the craftsman must perform prior to using the machine. These adjustments and setup procedures are intended to make the machine work and operate safely.

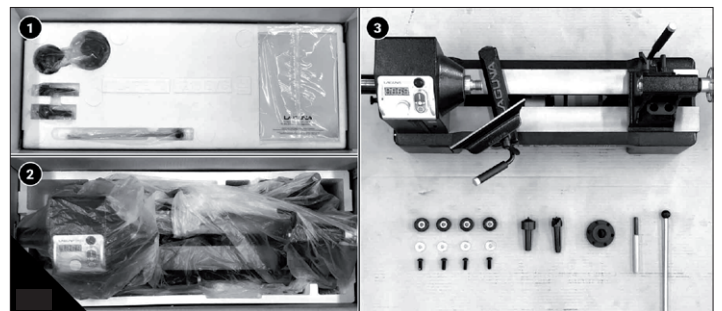

Fig. 10

**Fig. 10: Unpacking Revo 1216 Lathe. (1) Unpacking Contents. (2) Lathe in a box. (3) Components unpacked.**

### 6.1 Installing Rubber Levelling Pads

Rubber pads installed on the lathe reduce vibrations and protect the base from the floor. Do not install rubber pads if you are planning to use the stand.

Tools needed: 6mm Hex wrench

1. Make sure the lathe is unplugged and cannot be turned on.
2. Remove the tailstock and banjo (toolrest) from the lathe by releasing the cam lock and sliding it off the end. NOTICE: You do not need to unbolt anything to remove banjo or tailstock.
3. CAREFULLY tilt the lathe on its side. Use a blanket or similar soft thing to cushion the side of the lathe in contact with the floor.
4. Install a washer, rubber pad, and screw on each corner.

## 6.2 Installing/Removing Faceplate & Hand Wheel

**WARNING!** Unplug the machine from power source!

**TIP** Do not over torque the threading, only firm pressure is required.

**TIP** Remove set screws prior to removing faceplate. The screws are located on the flat part of the spindle. Do not disassemble by force.

Remove screws completely or you can damage the spindle.

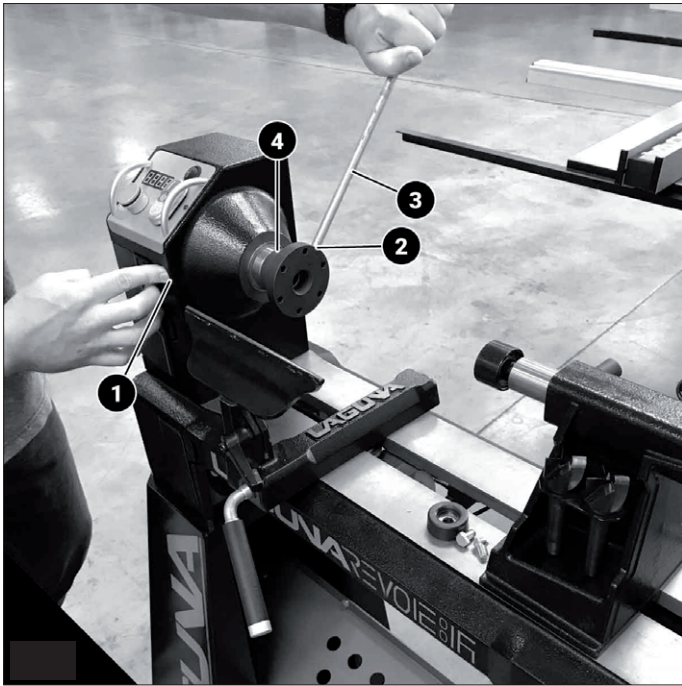

Fig. 11

**Fig. 11: Faceplate installation. (1) Spindle Lock. (2) Faceplate wrenching hole. (3) Knockout rod or Faceplate wrench. (4) Set screws.**

Simply screw the faceplate into the spindle threading. The spindle is with M33 x 3,5 mm right hand threads. There is a cutting slot on the spindle for the set screws.

Tools needed: Faceplate wrench (PLAREVO1836-1136) or Knockout rod (PLAREVO1216-1103A) and 3mm Hex wrench

1. Make sure the lathe is unplugged and cannot be turned on.
2. Position the banjo out of the way to prevent damage.
3. Check that the set screws (Key 4) are not engaged. Remove all set screws that are tightened down with Hex wrench.
4. Press the spindle lock (Key 1) inward to lock the spindle. Rotate the spindle a bit to line it up with the pin hole.
5. With spindle lock (Key 1) engaged and set screws removed, fit the faceplate wrench (Key 2) into the faceplate wrenching hole (Key 2).
6. Turn counter clock-wise to remove the faceplate, turn clock-wise to install the faceplate.
7. When installing, reverse these steps. **TIP** The faceplate wrench is not needed for the assembly. If you over-tighten the set screws you could damage the threading. Hand tightening is enough.

## 6.3 Installing/Removing Drive Centre and Live Centre

**Warning!** Unplug the machine from power source!

**TIP** Do not attempt to remove the live centre with tools, turn the quill until it pops out.

**TIP** The centres pop out quickly, prevent from dropping.

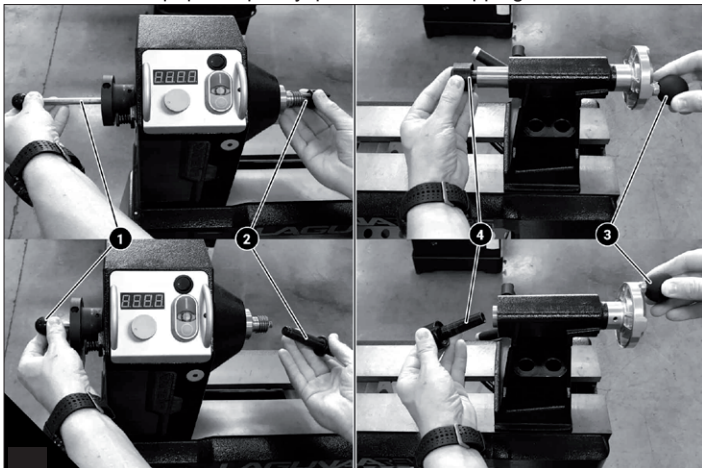

Fig. 12

**Fig. 12 - Centre Installation. (1) Knockout rod. (2) Drive Centre. (3) Quill Hand Wheel. (4) Live Centre.**

To install the centres, simply press them into the boring. When the workpiece is loaded both centres will be pressed into a firm position. Methods of centre installation vary.

## 6.4 Removing Drive Centre from Headstock

Tools needed: Knockout rod (PLAREVO1216-1103A).

1. Make sure the lathe is unplugged and cannot be turned on.
2. Lightly grasp the drive centre with free hand prior to step 3 - it will pop out unexpectedly.
3. Use the knockout rod (Key 1) and lightly tap on the centre.

## 6.5 Removing Live Centre from Tailstock

Tools needed: none

1. Lightly grasp the live centre with free hand prior to step 2 - it will pop out unexpectedly.
2. Turning the quill hand wheel (Key 3) counterclockwise will retract quill and release the live centre from the quill.

## 6.6 Changing Speed Range

**WARNING!** Unplug the machine from power source!

**CAUTION!** Pinching hazard. Do not rotate the spindle with hands in the belt cabinet.

**TIP** Do not attempt any other pulley configurations than those described below.

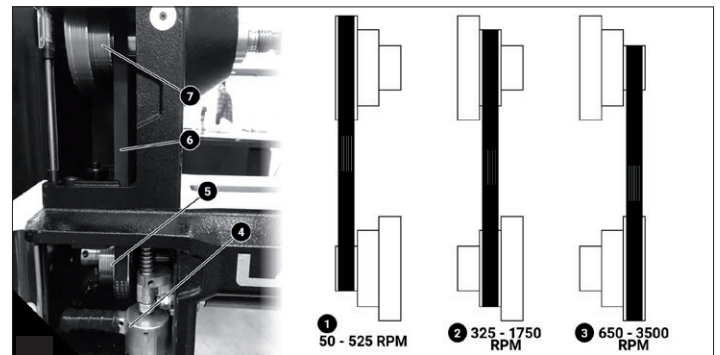

Fig. 13

**Fig. 13: Changing Speed Range. (1) Low Speed Range: 50-525 RPM. (2) Mid Speed Range: 325-1750 RPM. (3) High Speed Range: 650-3500 RPM. (4) Belt Tension Cam Handle. (5) Drive Pulley. (6) Groove Poly-V Belt. (7) Driven Pulley.**

The lathe has three sets of pulleys for high, medium, and low speed as described above. The belt should be tensioned so that there is approximately 3 to 6 mm (1/8 to 1/4") deflection when the belt is pressed with moderate thumb pressure. To adjust the amount of tension, see the Adjustment section. To adjust between the speed ranges, follow these steps:

Tools needed: none

Unplug the machine from power source!

2. Open both pulley covers to access upper (Key 7) and lower (Key 5) pulleys.
3. To loosen the belt tension, turn the belt tension cam handle (Key 4) towards you.
4. Move the drive belt (Key 6) to the required set of pulleys.
5. Tension the belt by returning the belt tension cam handle (Key 4) to its original position.
6. Test that the belt is set correctly by manually turning the spindle prior to returning power to the lathe.

## 7. Machine Operation

### 7.1 First Use

**WARNING!** Read the entire owners manual prior to using this machine.

**WARNING!** Never load or adjust the workpiece while the machine is switched on.

**CAUTION!** The workpiece must be balanced to limit vibrations.

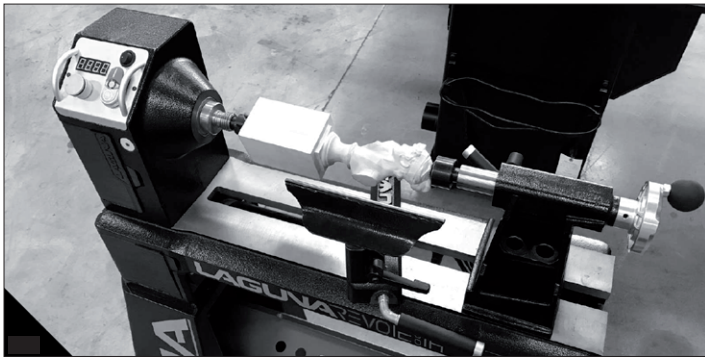

Fig. 14

Fig. 14: First use of 1216 lathe

## 7.2 Workpiece Clamping

1. Unplug the machine from power source. Install live centre into the tailstock prior to clamping a workpiece.
2. Find the centre of the workpiece to be mounted with either the faceplate or the drive centre. NOTE: A wood lathe chuck can also be used to clamp a workpiece. The chuck must be compatible with the M33 x 3.5 spindle threading.
3. Fasten the workpiece to the faceplate or mount the drive centre onto the centre of workpiece with a rubber mallet (NOTICE: do not use a metal hammer) or clamp the workpiece in the jaws of the chuck (skip step 4).
4. Insert the faceplate or drive centre into the spindle. NOTICE: You may need to remove the tailstock.
5. Replace the tailstock.
6. Fully release the quill by turning the hand wheel counter-clockwise.
7. Move the tailstock to the workpiece so that the live centre is circa 12 mm away from the workpiece.
8. Lock the tailstock in place with the cam lever.
9. Turn the hand wheel clockwise in order to seat the live centre into the centre of the workpiece. About 1/2 turn usually is enough, but it depends on the hardness of the workpiece.
10. Tighten the quill locking handle.
11. Check that the workpiece rotates freely by using the spindle hand brake prior to turning on the machine.

**CAUTION!** The workpiece must be balanced. Unbalanced workpiece may vibrate too heavily and cause problems. Especially with live edge pieces, remove any large abnormalities prior to clamping the workpiece. A balanced workpiece will not assume any rotation orientation.

## Personal protection and safety

Make sure to completely read and understand this manual. It is necessary to follow these instructions to limit danger when using this machine.

## 7.3 Turning on the Lathe

1. Confirm that the belt is in the correct speed range. For speed range adjustments see Changing Speed Range
2. Use appropriate personal protective equipment.
3. Confirm that all chisels and work tools are within close range and do not require any reaching over the workpiece.
4. Plug in the machine to the appropriate socket.
5. Double check the workpiece balancing and rotation.
6. Turn on the lathe.

**CAUTION!** Do not start the lathe at maximum speed with a clamped workpiece. Start at the lowest speed within chosen range. Then gradually increase the speed.

## 8. Accessories

The following accessories are designed for the Revo 1216 Lathe. These instructions should be followed exactly to properly set up the equipment. Some of these accessories are designed to fit multiple machines offered by Laguna Tools.

### IGM LAGUNA Revo 1216 Expansion Set 254 mm

Order code: 151-1216EXT

Compatibility: 151-1216

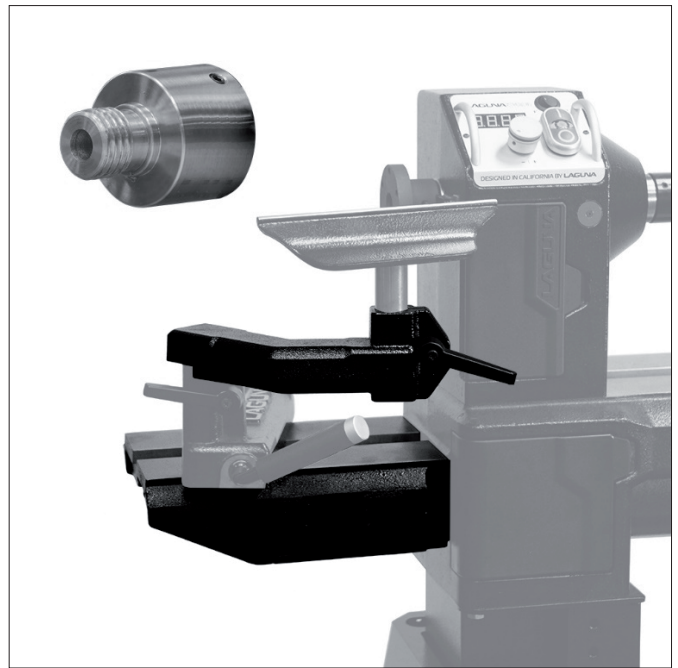

Fig. 15

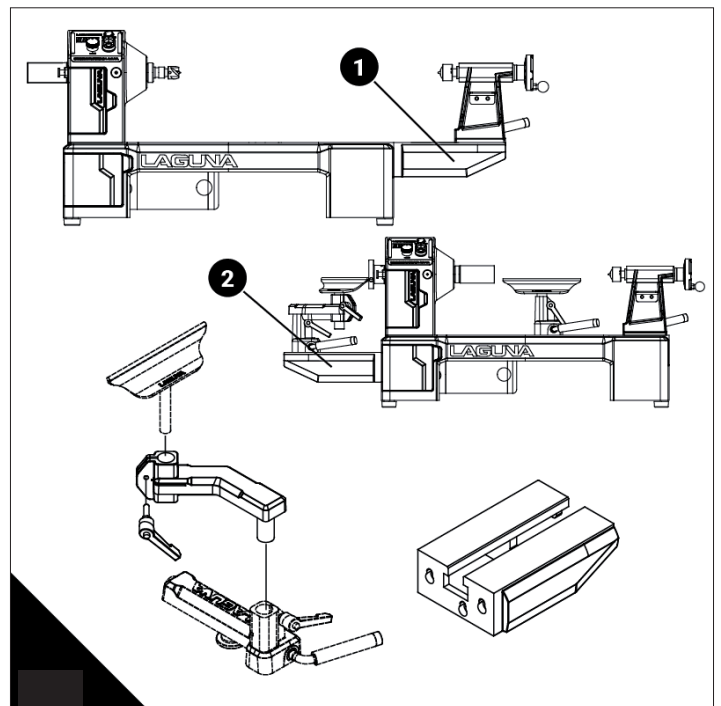

Fig. 16

Fig. 16: (1) Bed extension - increased centre to centre from 393 mm to 647 mm. (2) Outboard turning - allows for 406 mm outboard turning capacity

The lathe features forward and reverse spindle rotation as well as a double threaded spindle that allows turning on both sides of the lathe. The user can choose to extend the centre to centre capacity by 254 mm or outfit their lathe for outboard turning.

### Contents:

The expansion set consist of 3 parts: 254 mm cast iron extension that can be mounted on the right or left side of the lathe. Toolrest extender for outboard use. Adapter that allows chucks with M33 x 3,5 mm to be used.

**CAUTION!** You have to use a reversible chuck with set screws attached for outboard turning. Always tighten the set screws on the faceplate or chuck to the spindle adapter / spindle for outboard turning.

### Revo 1216 Expansion Set Setup

**WARNING!** Unplug the machine from power source!

**TIP** Do not over torque the threading, only firm pressure is required.

**TIP** The toolrest extension (2.2) and lock handle (2.4) are only used when outboard turning.



Tools needed: Hex wrench

### Receiving

It is likely that your machine will be delivered by a third party. Before unpacking, be sure to inspect the packaging and shipping documents supplied by the driver. If any damage has occurred because of shipment, note the damage on the bill of lading or refuse the shipment. Immediately call the dealer store where the machine was purchased.

1. Never accept a shipment that is damaged or partial without notifying the shipping company and the purchasing store.

### Stand unpacking

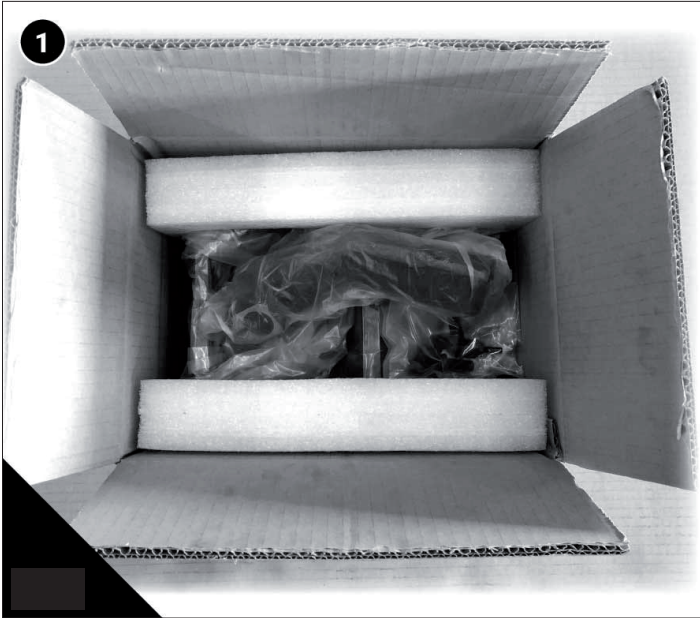

Fig. 17

**Fig. 17: Unpacking Revo 1216 Expansion Set 254 mm. (1) Delivery contents. (2) Components unpacked. (2.1) Extension Bed 254 mm. (2.2) Toolrest Extension. (2.3) Extension Bed Bolts. (2.4) Lock Handle. (2.5) Outboard Adapter.**

Once in place, carefully unpack and remove all components. Unpacking guidelines:

1. Do not cut deep into a box with a blade as it could scratch the paint. Only cut deep enough to cut the tape or use a dull edge.
2. Organize the tools needed prior to proceeding with setup.

Components (Expansion Set 254 mm)

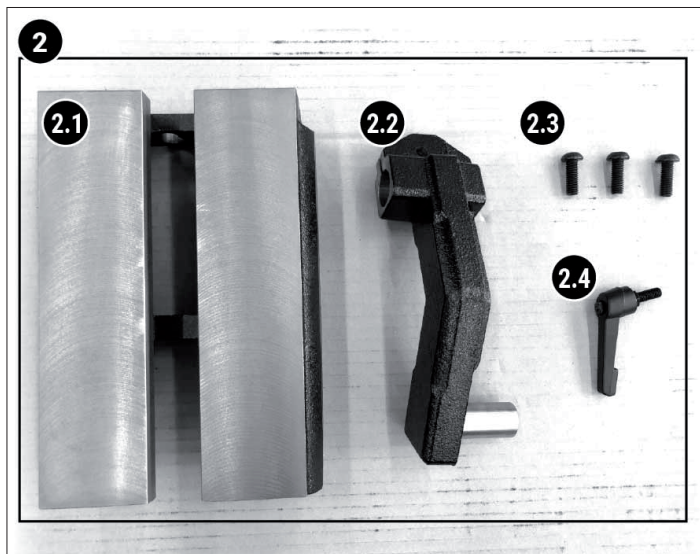

Fig. 18

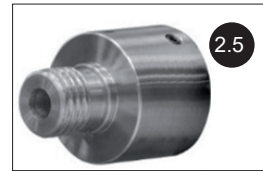

Fig. 19

**Fig. 17 - Fig. 19: Unpacking Revo 1216 Expansion Set 254 mm. (1) Delivery contents. (2) Components unpacked. (2.1) Extension Bed 254 mm. (2.2) Toolrest Extension. (2.3) Extension Bed Bolts. (2.4) Lock Handle. (2.5) Outboard Adapter.**

### Inventory

Key	Name	Description
2.1	Extension Bed	Extends the bed length of the lathe or can be installed to the left side for outboard turning.
2.2	Toolrest Extension	Only to be used when outboard turning to raise the toolrest to the appropriate position.
2.3	Hex Screws	Attaches extension to the end of the bed or to the lower outboard turning position.
2.4	Lock Handle	Locks the toolrest extension (2.2) in place.
2.5	Adapter	Adapter M33 x 3,5 mm

### Setup Procedure

1. Make sure the lathe is unplugged and cannot be turned on.
2. Remove the tailstock and banjo (tool rest) by releasing the cam locks and carefully sliding them out from the right side of the lathe.

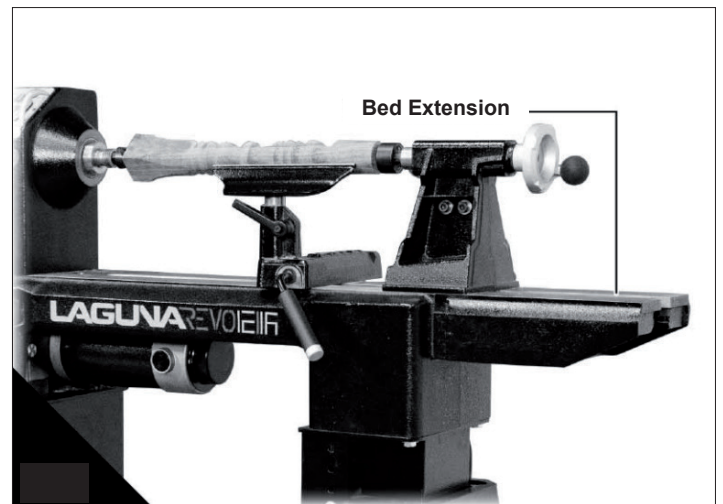

Fig. 20

3. The bolt holes are pre-tapped. Lightly tighten all 3 screws (Key 2.3) and slide the extension into the right side.
4. Reattach toolrest and tailstock. Position the tailstock so that half rests on the bed and half rests on the extension (Fig. 20). Align the extension and the bed, then tighten the screws.

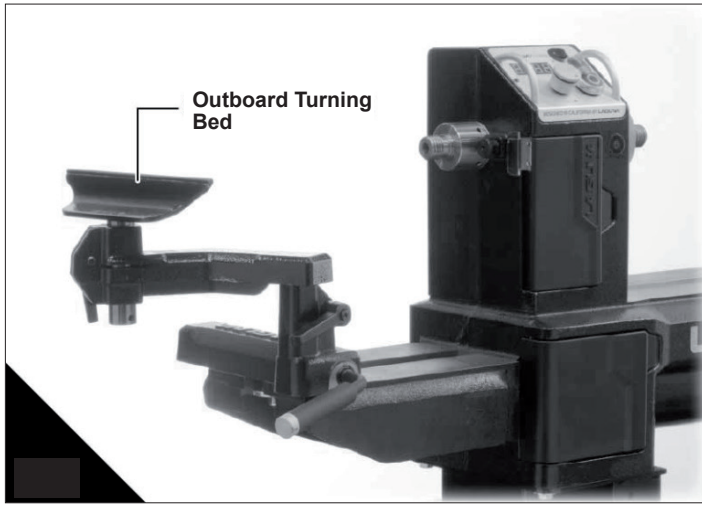

Fig. 21

5. Place the tailstock on the main bed for safe keeping.
6. The bolt holes are pre-tapped. Lightly tighten all 3 screws (Key 2.3) and slide the extension into the left side.
7. Remove hand wheel or faceplate from left spindle threading.
8. Loosen outboard adapter set screws, lock spindle and screw in the outboard adapter (Key 2.5).
9. Install the banjo on the extension by carefully sliding it into the left side of the extension.
10. Install the toolrest extension (Key 2.2) into the neck of the banjo.
11. Install the lock handle (Key 2.4) into the toolrest extension (Key 2.2).
12. Install the toolrest into the toolrest extension (Key 2.2).

**IGM LAGUNA Revo 1216 Adjustable Stand**

Order code: 151-1216STA  
 Compatibility: 151-1216



Fig. 22

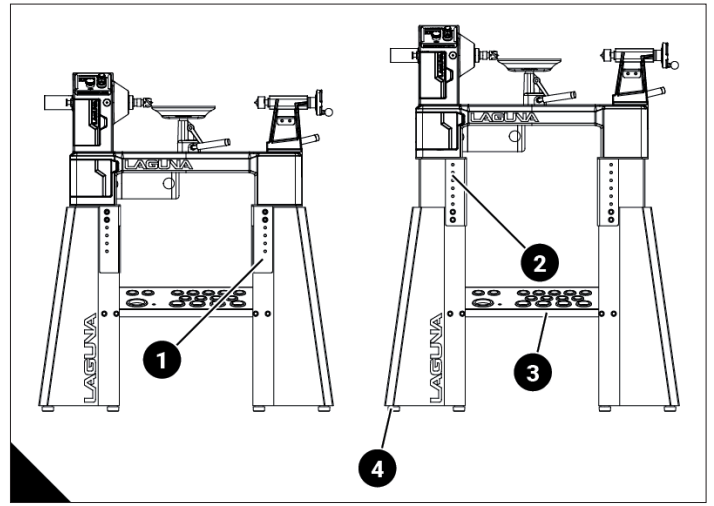

Fig. 23

**Fig. 23: Revo 1216 Adjustable Stand. Includes adjustable lathe stand and a tool rack. (1) Lowest position 990 mm (floor to spindle centreline). (2) Highest position 1143 mm. (3) Tool Rack - holds faceplate, both centres, knockout rod, 9 chisel tools with 25 mm holes and 4 large tools with 34 mm holes. (4) Rubber Pads.**

**Revo 1216 Adjustable Stand Setup**

**WARNING!** Unplug the machine from power source!

**CAUTION!** Two persons are required in this setup.

**TIP** Do not over torque the threading, only firm pressure is required.

Tools needed: Additional person, 6 mm Hex wrench, Phillips head screwdriver and open ended wrench.

**Receiving**

It is likely that your machine will be delivered by a third party. Before unpacking, be sure to inspect the packaging and shipping documents supplied by the driver. If any damage has occurred because of shipment, note the damage on the bill of lading or refuse the shipment. Immediately call the dealer store where the machine was purchased.

1. Never accept a shipment that is damaged or partial without notifying the shipping company and the purchasing store.

**Stand unpacking**

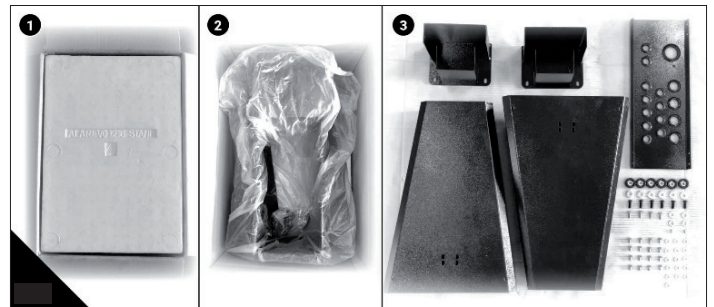

Fig. 24

**Fig. 24: Unpacking Revo 1216 Adjustable Stand. (1) Contents. (2) Stand in a box. (3) Contents unpacked.**

Once in place, carefully unpack and remove all components. Unpacking guidelines:

1. Do not cut deep into a box with a blade as it could scratch the paint. Only cut deep enough to cut the tape or use a dull edge.
2. Organize the hardware and setup tools needed prior to proceeding with setup.

## Inventory

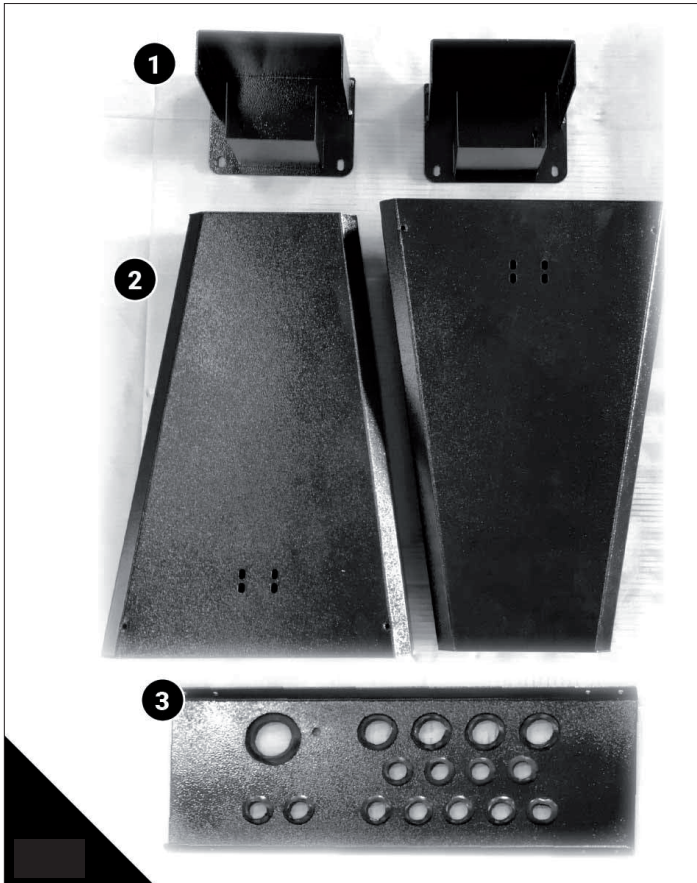

Fig. 25

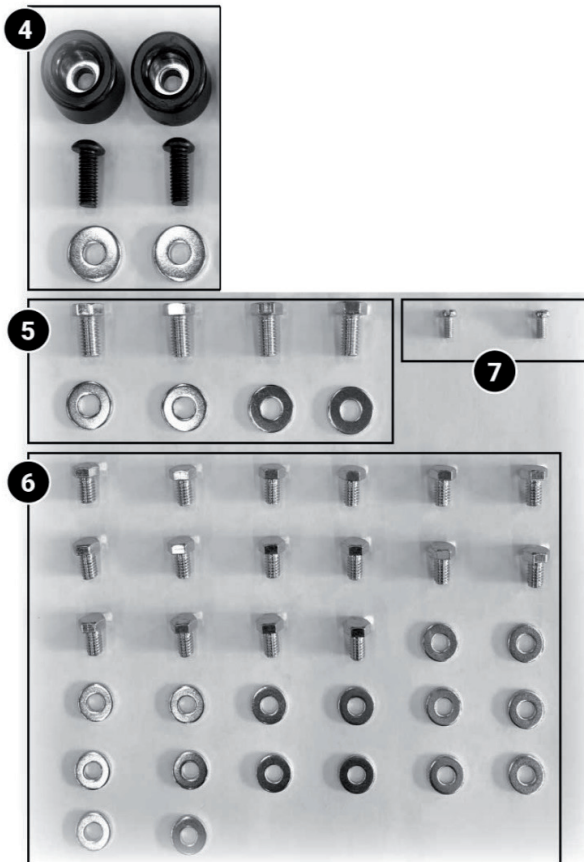

Fig. 26

Fig. 26: Revo 1216 Adjustable Stand Inventory.

(1) Adjustable height pillars. (2) Stand Leg. (3) Tool Rack. (4) Rubber pads, screws and washers. (5) Lathe attachment bolts and washers. (6) Bolts and washers for assembly. (7) Height constraint screws.

Key	Name	Description
1	Height Pillar PLAREVO1216-204	Main contact point from lathe to stand. Allows for adjustable height.
2	Stand Leg PLAREVO1216-201 PLAREVO1216-202	Sheet Steel constructed stand leg. Has pre-tapped holes to mount. <b>TECH TIP</b> These legs are not the same. You will notice that the bolt holes that connect the organization shelf are not at the same height. The lower positioned bolts holes must be front.
3	Organization Shelf PLAREVO1216-203	Adds structural stability to stand. Also holds 13 turning chisels/tools and all functional set-up tools.
4	Rubber Pads /Bolts/Washer	Used on the bottom of the stand legs to minimize vibration.
5	Lathe Bolts/Washer	Lathe to stand Fasteners.
6	Assembly Hardware	Height adjustment fasteners, shelf to leg fasteners,
7	Height Constraint Screw	Positions maximum height of lathe stand.

### Setup Procedure

1. Make sure the lathe is unplugged and cannot be turned on.
2. Remove the rubber pads from the lathe. This will give 6 rubber pads, 6 hex bolts and 6 washers.
3. Install the rubber pads (Key 4) to the stand legs (Key 2) with Hex screws and washers.

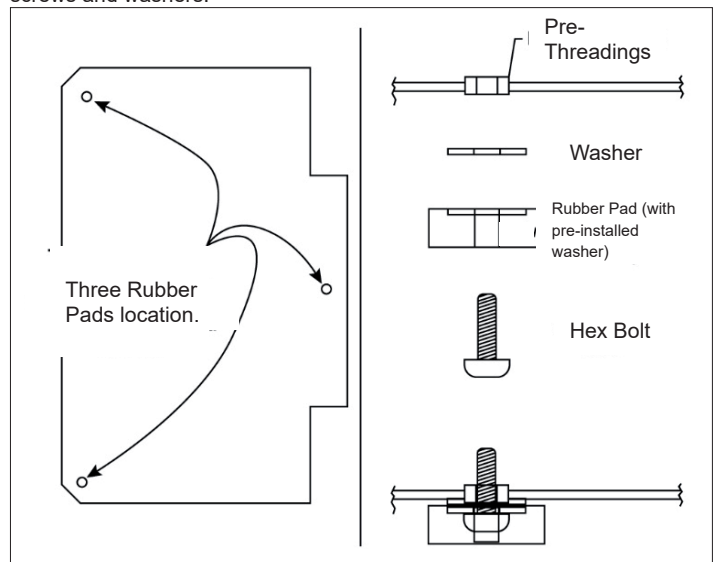

Fig. 27

4. Identify the left and the right leg. There are four bolt holes on each leg for the rack (Key 3). The upper two bolt holes must face the rear of the machine, the lower two bolt holes must face the front of the workspace. The rack is then installed so that it is angled towards the operator.
5. Identify the correct orientation of the tool rack (Key 3). The lip of the rack should not be visible. In Fig. 17 the shelf is upside down. A properly installed rack should have the largest hole (faceplate storage) on the furthest left and towards the operator.
6. Fasten the stand legs to the tool rack. Use 8 bolts and washers (Key 6). Tighten all screws at the end of the setup. **TIP** The stand will not be rigid until it is fastened to the lathe. Once the lathe is attached and the height is adjusted properly, it will be very rigid.
7. Install the height pillars (Key 1) to the stand legs with the remaining eight bolts and washers (Key 6). Tighten all screws at the end of the setup. **TIP** Assuming the final height now is easier than later. Nevertheless it can be positioned later.
8. Carefully reach into the stand leg and install the height constraint screw on each pillar (Key 7). These screws will prevent the operator from pulling the lathe out of the stand.
9. Using an additional person, place the lathe onto the stand. Attach the lathe to the stand. **CAUTION!** One person must focus on holding the position of the lathe while the other positions the four bolts and washers (Key 5).
10. Tighten all bolts.
11. For safety, remove the lathe away from the stand if you would like to change the height.
12. Avoid over tightening.

**IMPORTANT:** If the lathe is not level

1. Make sure the lathe is mounted to the stand.
2. Make sure floor is flat.
3. Loosen all 16 bolts holding height position pillars and tool rack to relieve all gaps.
4. Retighten all bolts.

**IMPORTANT:** If using the mobility kit, please remove the two rubber feet closest to the two stationary wheels of the mobility kit.

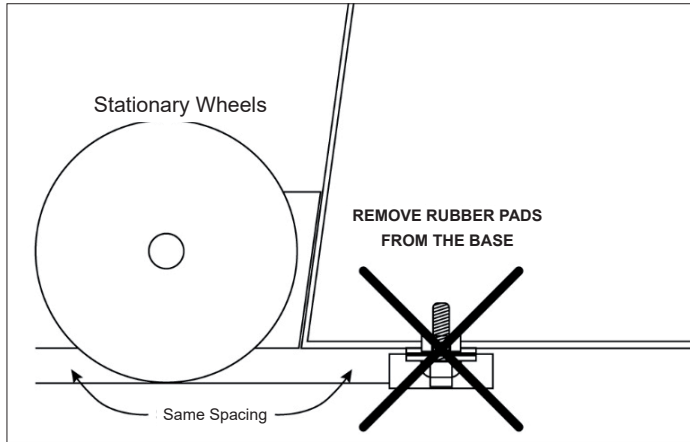

Fig. 28

**FAQ**

Q: What is the height range with this stand?

A: The Revo 1216 Stand allows the spindle center line to be positioned at 7 different heights from 990 mm (39") to 1143 mm (45").

Q: Does this come with the mobility kit?

A: No, it comes standard with rubber pads.

**IGM LAGUNA Mobility Kit for 1412-14BX-1216**

Order code: 151-1412MBA

Compatibility: 151-1216STA, 151-1412, 151-14BX

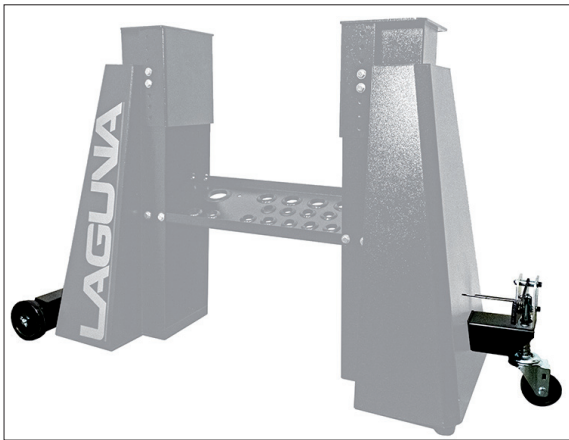

Fig. 29

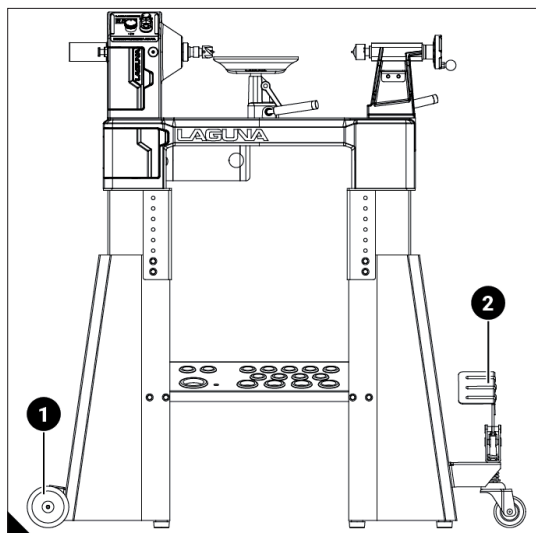

Fig. 30

Fig. 30: Mobility Kit for Revo 1216 Lathe. (1) Base Wheels & mounting. (2) Foot Lever and Wheel Mount Assembly

**Mobility Kit Setup**

**WARNING!** Unplug the machine from power source!

**TIP** Do not over torque the threading, only firm pressure is required.

**TIP** Revo 1216 Adjustable Stand must be purchased to use the Mobility Kit.

**Receiving**

It is likely that your machine will be delivered by a third party. Before unpacking, be sure to inspect the packaging and shipping documents supplied by the driver. Ensure that there is no visible damage to the shipment. If any damage has occurred because of shipment, note the damage on the bill of lading or refuse the shipment. Immediately call the dealer store where the machine was purchased.

1. Never accept a shipment that is damaged or partial without notifying the shipping company and the purchasing store.

**Stand unpacking**

Once in place, carefully unpack and remove all components.

Unpacking guidelines:

1. Do not cut deep into a box with a blade as it could scratch the paint. Only cut deep enough to cut the tape or use a dull edge.
2. Organize the hardware and setup tools needed prior to proceeding with setup.

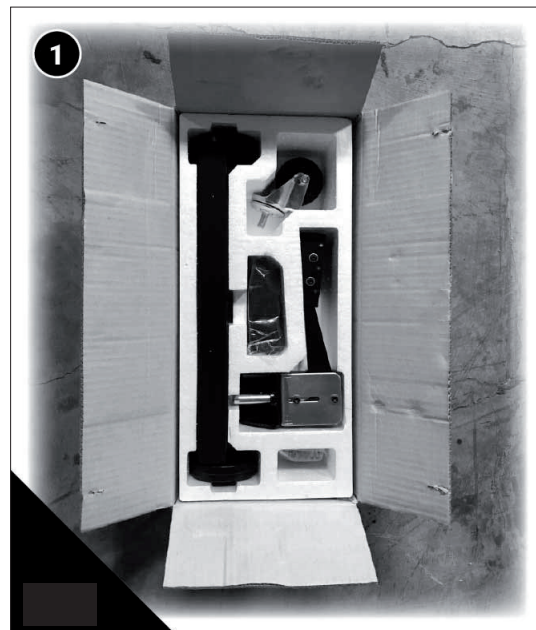

Fig. 31

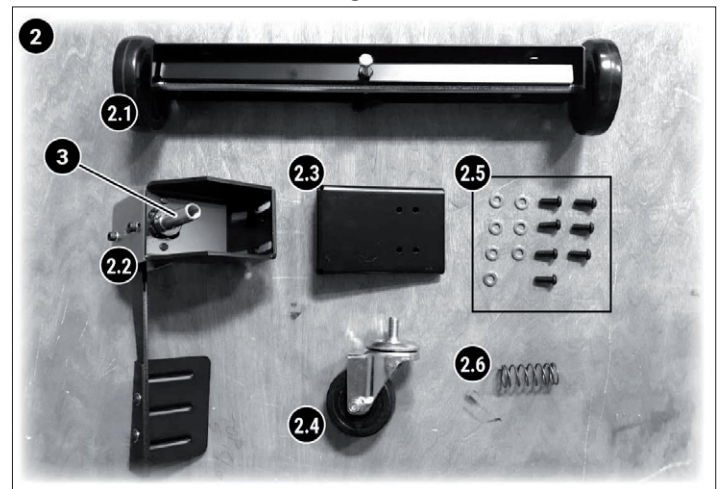

Fig. 32

Fig. 32: Unpacking (1) Contents. (2) Unpacked Contents. (2.1) Stationary Wheels. (2.2) Foot Pedal Assembly. (2.3) Support Plate. (2.4) Foot Pedal Caster. (2.5) Hardware. (2.6) Foot Pedal Spring. (3) Swivel Axle.

## Inventory

Key	Name	Description
2.1	Stationary Wheels	Can be mounted on left or right stand leg. Must be positioned so that the machine is off the floor when the foot pedal is engaged.
2.2	Foot Pedal Assembly	Must be positioned so that the machine is off the floor when the foot pedal is engaged.
2.3	Support Plate	Mounts to the (inside) stand leg with foot pedal assembly (2.2).
2.4	Foot Pedal Caster	Mounts to foot pedal assembly (2.2).
2.5	Lathe Bolts and Washers	Used to fasten the wheels to the machine base.
2.6	Foot Pedal Spring	Installs in between the caster (2.4) and the assembly (2.2).
3	Swivel Axle	Axle that spring (2.6) and caster (2.4) are installed to.

## Setup Procedure

Tools needed: Hex wrench, open ended wrench

### Installing the Stationary Wheels

1. Make sure the lathe is unplugged and cannot be turned on.
2. Install the stationary wheels (Key 2.1) to either the left or the right stand leg with 2 bolts and washers (Key 2.5). **TIP** Choose more suitable side for mounting stationary wheels. It is often best to have the foot pedal caster on the right side and the stationary wheels on the left side.
3. Remove the 2 rubber pads closest to the stationary wheels.
4. Make sure that the wheels are in contact with the floor and in the same height.

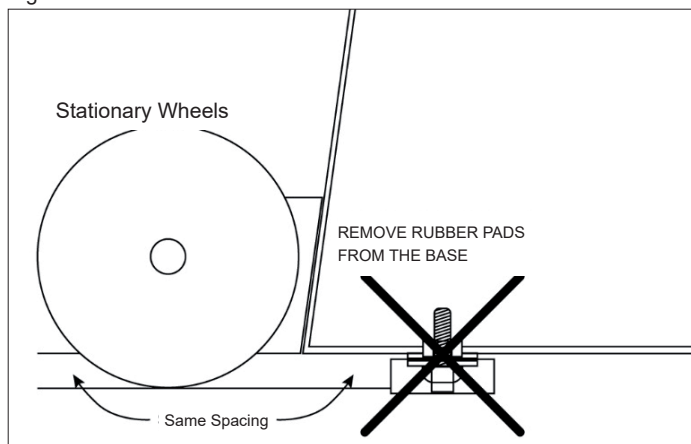

Fig. 33

### Installing the Foot Pedal Assembly and Wheel

- The order of the assembly is: support plate, stand leg, foot pedal assembly. The bolts thread into the support plate (Key 2.3). The support plate is installed to the inside of the opposite stand leg that the stationary wheels were installed to.
5. Place the foot pedal spring (Key 2.6) on the swivel axle (Key 3) of the foot pedal assembly. Screw the foot pedal caster (Key 2.4) onto the swivel axle.
  6. Tighten the foot pedal caster with open ended wrench.
  7. Release the foot pedal.
  8. Place one bolt in the foot pedal assembly bolt slot.
  9. Put together support plate, stand leg and foot pedal caster assembly. Finger tighten the bolt.
  10. Finger tighten the remaining bolts (Key 2.5). **TIP** We supply an extra bolt.
  11. When the foot pedal is not engaged, the foot pedal caster wheel should be approximately at the same level as the rubber pads. Tighten all bolts.

## FAQ

Q: Does the wheel system affect the height of the lathe?

A: No, the two left wheels will always be in contact with the floor but only at the same level as the caster. When the pedal is engaged the lathe will prop up on the 3 wheels and is mobile. Releasing the pedal puts the machine back on the floor.

## IGM LAGUNA Industrial Flood Light for Revo1836-1412-14BX-18BX

Order code: 151-1836L

Compatibility: 151-1836, 151-18BX, 151-1216, 151-1412, 151-14BX

L-bracket for connecting the light to the rear of the headstock is not part of the light supply, inquire about the options with your supplier:

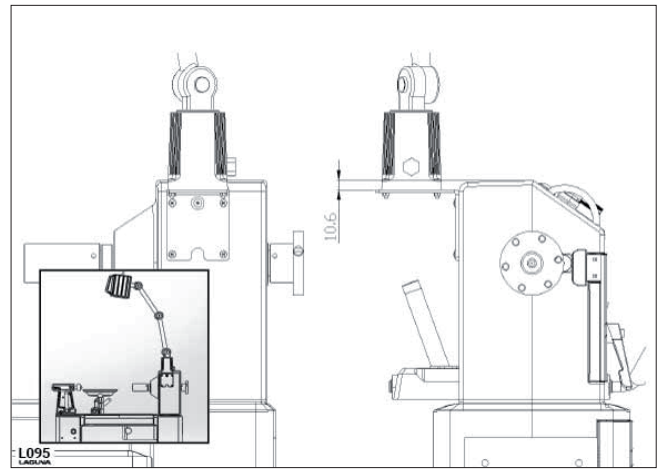

Fig. 34

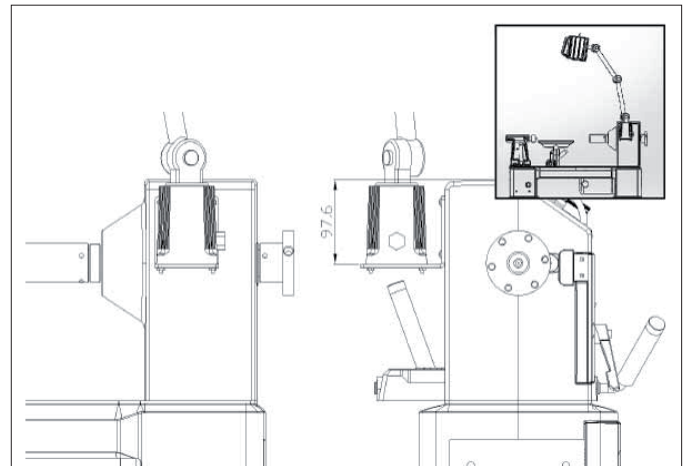

Fig. 35

## 9. Maintenance

**WARNING!** Unplug the machine from power source!

**WARNING!** If you have any doubt about the described procedure, seek professional assistance. Do not attempt any procedure that you feel is unsafe, or that you do not have the physical capability of achieving.

**WARNING!** When removing packaging banding, extreme caution must be used as the banding will spring when cut.

**CAUTION!** The machine is heavy. Ensure that you have enough people to do the job safely.

**TIP** There may be sawdust in or around your new machine as a result of thorough testing.

### General Notes

Keep your machine clean At the end of each work day, clean the machine. Wood contains moisture. If sawdust or wood chips are not removed they will cause rust. We recommend that you only use a Teflon based lubricant. Regular oil attracts dust and dirt. Teflon lubricant tends to dry and has less of a tendency to accumulate dirt and saw dust. Periodically check that all nuts and bolts are tight.

### Drive Belt

The drive belt should last for many years (depending on the usage) but needs to be inspected regularly for cracks, cuts and general wear. If damage is found, replace the belt.

### Bearings

All bearings are sealed for life and do not require any maintenance. If a bearing becomes faulty, replace it.

### Rust

The lathe is made from steel and cast iron. All non-painted surfaces will rust if not protected. We recommend to protect the lathe by applying wax or a Teflon based lubricant.

### Changing the Belt and the Bearings

**WARNING!** Unplug the machine from power source!

**TIP** Do not over torque the threading, only firm pressure is required.

**TIP** Do not attempt to remove pulleys before removing set screws.

**WARNING!** Changing belt and bearings can be a difficult task and should be performed by an authorized repair station.

Remove headstock and take it to a repair station for servicing.

1. Unplug the machine from power source.
2. Open lower door and loosen the tension handle.
3. Remove the belt from the lower pulley

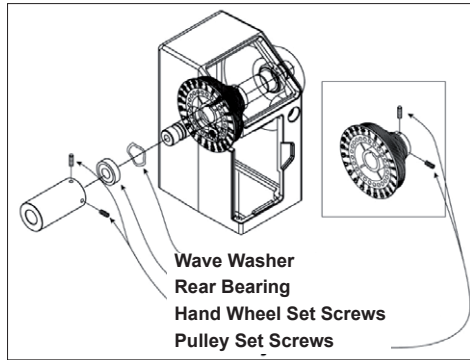

Fig. 36

4. Remove two set screws from the hand wheel.
5. Remove the hand wheel from the spindle by pushing in the spindle lock and turning the hand wheel counter-clockwise.
6. Loosen 2 set screws in the upper pulley.
7. Use a wooden dowel or aluminium stock to knock spindle towards the tailstock. Use a material that is softer than the spindle, so you do not damage it. Remove the belt from the spindle.
8. Replace the belt or bearings.
9. Reverse these steps to reassemble.

**TIP** There is a wave washer between the right side of the upper pulley and a black magnetic ring on the spindle. The black magnetic ring is seated on the shoulder of the spindle. It is important for spindle speed sensing. Make sure the upper pulley is pushing against the wave washer. If not, the ring could slip on the spindle while you tighten the set screws in the upper pulley. This will cause inaccurate spindle speed data on the control panel.

**TIP** Tighten the hand wheel by hand

#### Lathe will not start.

1. Check that the start switch is in the correct position.
2. Check that the power cord is plugged into the socket.
3. Check that the electrical supply is on (reset the breaker).
4. With the power disconnected from the machine, check that the wiring to the plug is correct.
5. Check that the rubber insulation is stripped enough and is not causing a bad connection. Check that all the screws are tight.

#### The machine will not stop.

This is a very rare occurrence as the machine is designed to be fail-safe. If it should occur and you cannot fix the fault, seek professional assistance. The machine must be disconnected from the power and never run until the fault has been rectified.

1. The stop switch is faulty. Replace the stop switch.

#### Motor tries to start but will not turn.

1. With the power disconnected, try to turn the spindle by hand. If the spindle will not turn, check the reason for jamming.
2. Capacitor faulty. Replace the capacitor.
3. Motor faulty. Replace the motor.
4. Power line overloaded. Correct overloaded condition.
5. Low voltage. Correct low voltage condition.

#### Squeaking noise.

1. Check the bearings.
2. Check the drive belt is tensioned correctly.

#### Spindle slows down during a cut.

1. Dull cutting tools. Replace the tool or have it resharpened.
2. Feeding the wood too fast. Slow down the feed rate.
3. Oil or dirt on the drive belt. Clean or replace the drive belt.
4. Drive belt loose. Re-tension drive belt.

#### Machine vibrates.

1. Machine not level on the floor. Re-level the machine ensuring that it has no movement.
2. Damaged drive belt. Replace the belt.
3. Workpiece is not balanced. Change to slower speed and/or balance the workpiece.
4. Damaged pulley. Replace the pulley.
5. Worn spindle bearing. Replace the bearing.

#### Digital Read Out (DRO) is displaying an error.

##### Err1:Over-current mode

If the operating current of the motor exceeds 10 Amps for 30s, the control board goes into Over-current mode.

Over-current mode stops the motor immediately and the display shows Err1. Do not use the lathe in reverse mode with the lowest revolution range on the pulley (Slow: 50-100; Medium: 325-450; Fast: 650-950 RPM). At this range, the over-current mode is triggered.

To release the Over-current mode:

- Press the STOP button.
- Press the START button. Control panel restarts the motor.

##### Err2: Motor work fail mode

After pressing the start button, if the motor is not running after 25s, the control panel enters the Motor work fail mode

In the motor work fail mode, the control board immediately stops the motor operation and the display shows Err2.

To release the Motor work fail mode:

- Press the STOP button.
- Press the START button. Control panel restarts the motor.

##### Err3:Spindle work fail mode

After pressing the START button, if the control board detects that the spindle is not running for 30 seconds after the motor runs normally, it will enter the Spindle work fail mode.

Spindle work fail mode immediately stops the motor and the display shows Err3.

To release the Spindle work fail mode:

- Press the STOP button to release the Spindle work fail mode.
- Press the START button. Control panel restarts the motor.

#### Wiring

**VOLTAGE.** Before connecting this tool to a power supply make sure that the voltage is the same as on the nameplate of the tool. **IF IN DOUBT, DO NOT PLUG IN THE MACHINE.** Using this tool with a voltage different than that stated on the nameplate can damage the electrical components of this machine and any such damage will not be covered by a warranty.

**CIRCUIT BREAKER** Also make sure that the power supply is equipped with the appropriate breaker and plug according to your local electrical code. First check the motor plate to get the FLA amperage of the machine. If it is worn out or not present, refer to the specifications sheet. If there is any doubt in choosing the appropriate circuit breaker, please consult an electrician.

**ELECTRICAL SHOCK** It is extremely dangerous to work on live wires and other electrical systems that are connected to a power source. Unplug the machine from power source!

**MOTOR WIRING:** The information in this manual was current at the time of printing but may be different than the diagram on your machine. ALWAYS use the supplied wiring diagram with the machine or motor (under the electrical covering) if present.

#### Parts

Unplug the machine from power source!

Only use authentic Laguna Tools parts for replacements.

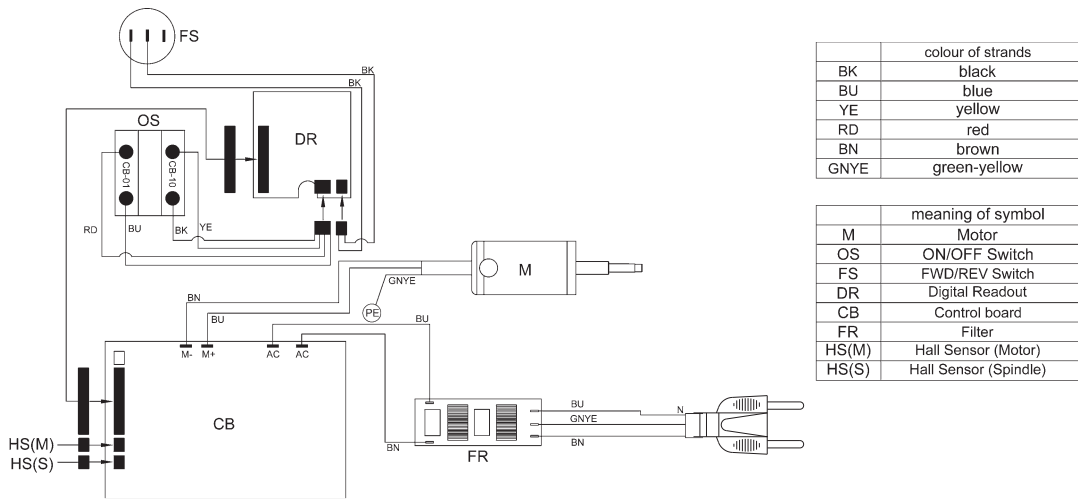

**Revo 1216 Banjo, Tool Rest, Tail Stock, Centers**

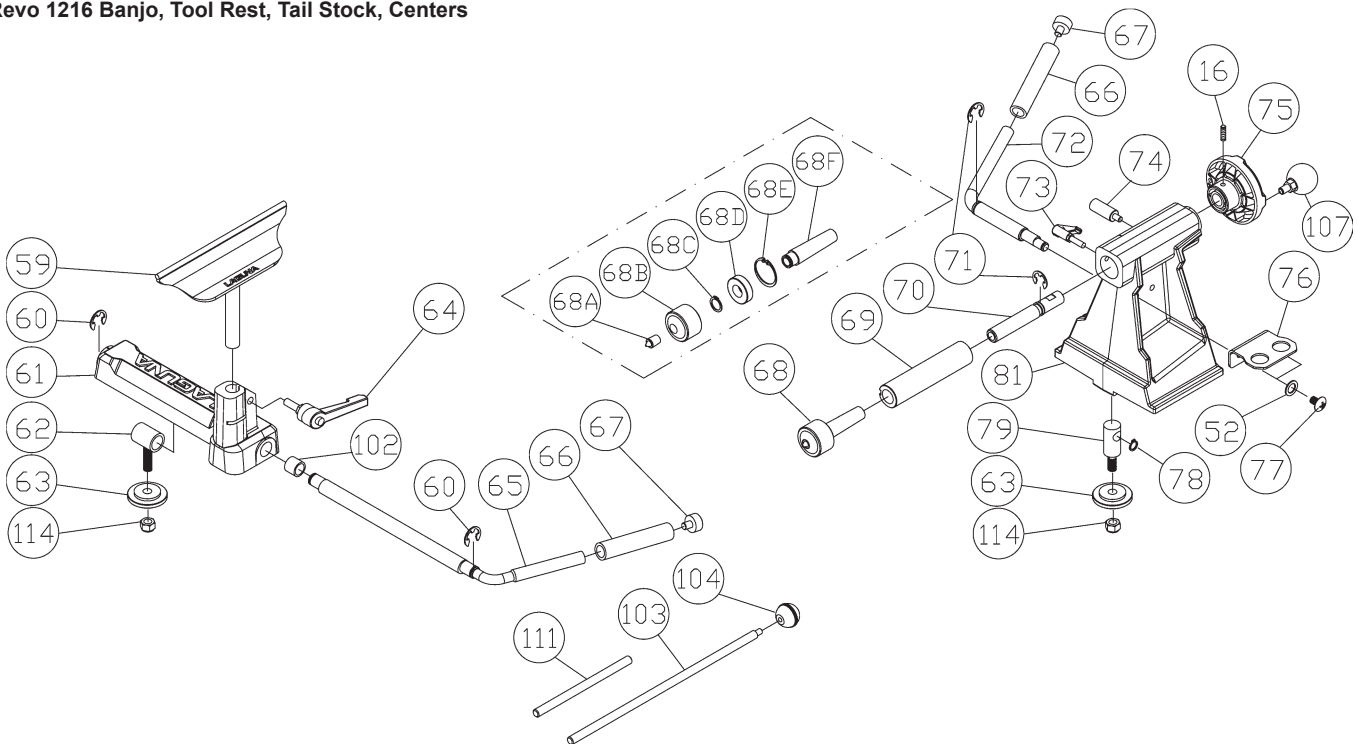

Key	Part Number	Description	Specification	Qty
16	PLAREVO1836-1119	Set Screw	1/4-20UNCx3/8"	5
52	PLAREVO1836-1113	Flat Washer	D8xD18x2t	3
59	PLAREVO1216-159	8" Tool Rest		1
60	PLAREVO1216-160	E-RING	E-10	2
61	PLAREVO1216-161	Tool Rest Support Base		1
62	PLAREVO1216-162	Clamp Bolt		1
63	PLAREVO1216-163	Clamp		2
64	PLAREVO1216-164	Lock Handle		1
65	PLAREVO1216-165	Tool Rest Locking Handle		1
66	PLAREVO1216-166	Rubber Sleeve		2
67	PLAREVO1216-167	Cap		2
68	PLAREVO1216-168	Live Center Assembly		1
69	PLAREVO1216-169	Quill		1
70	PLAREVO1216-170	Lead Screw		1
71	PLAREVO1216-171	E-RING	E-12	2
72	PLAREVO1216-172	Tailstock Locking Handle		1
73	PLAREVO1216-173	Lock Handle		1
74	PLAREVO1216-174	Stop Bolt		1
75	PLAREVO1216-175	Handwheel		1
76	PLAREVO1216-176	Tailstock Tool Caddy		1
77	PLAREVO1216-177	Screw 5/16-18UNCx1/2"		2
78	PLAREVO1216-178	C-RING S10		1
79	PLAREVO1216-179	Clamp Bolt		1
81	PLAREVO1216-181	Tailstock		1
102	PLAREVO1216-1102	bushing		1
103	PLAREVO1216-1103	Knockout Rod		1
104	PLAREVO1216-1104	Knob		1
107	PLAREVO1836-181	Knob		1
111	PLAREVO1836-1136	Handle, Faceplate		1
114	PLAREVO1216-1114	Nylon Insert Lock Nut	3/8-16UNC	2

## Revo 1216 Headstock Assembly

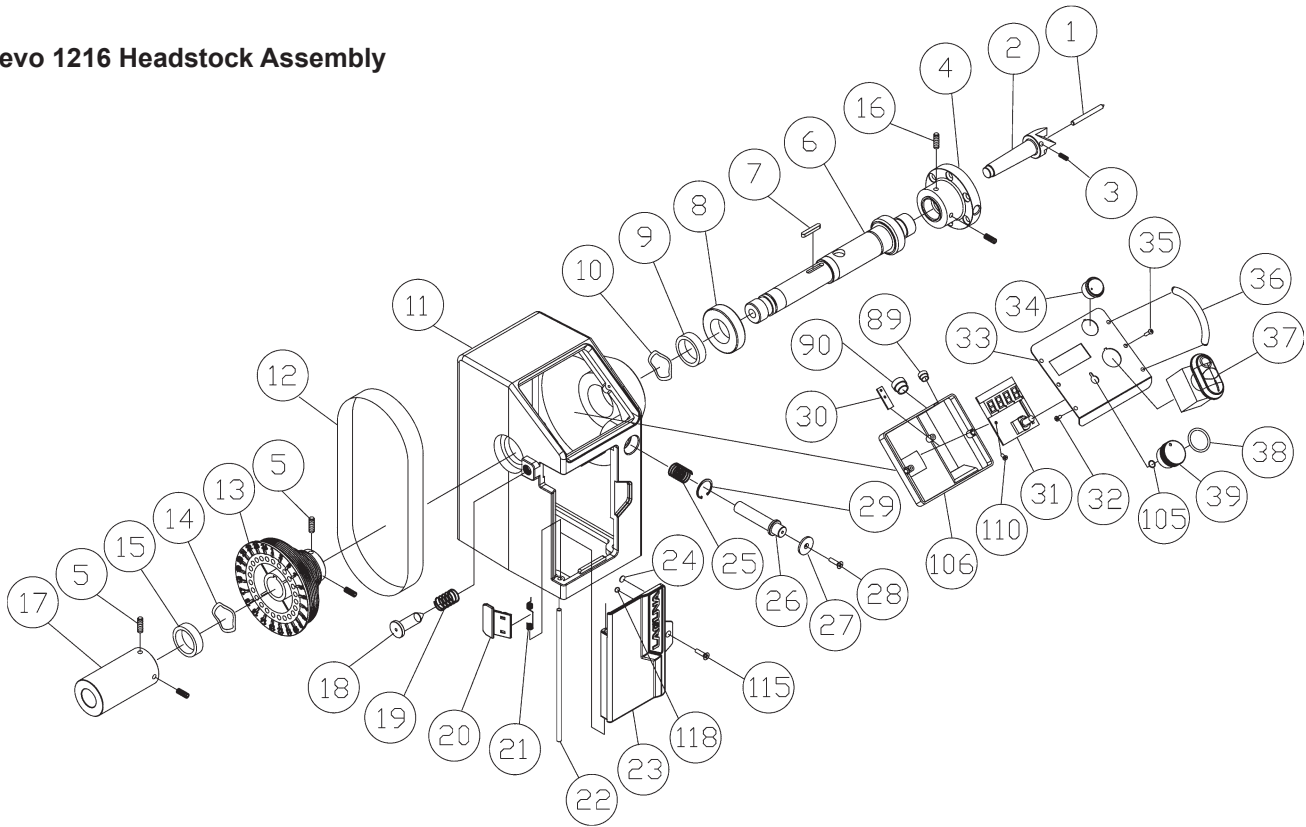

Key	Part	Number	Description	Specification	Qty
1	PLAREVO1836-1140		Thimble		1
2	PLAREVO1836-124		Spur Center		1
3	PLAREVO1836-1124		Set Screw	M6x1.0x6mm	1
4	PLAREVO1216-104-UK		3" Faceplate		1
5	PLAREVO1836-1101		Set Screw	1/4-20UNCx1/4"	6
6	PLAREVO1216-106-UK		Spindle		1
7	PLAREVO1216-107		Key	5x5x25mm	2
8	PLAREVO1216-108		Ball Bearing	6006LLU	1
9	PLAREVO1216-109		Magnetic ring		1
10	PLAREVO1216-110		Wave Washer	6202	1
11	PLAREVO1216-111-UK		Headstock		1
12	PLAREVO1216-112		Poly-V Belt	PJ6-290	1
13	PLAREVO1216-113		Spindle Pulley		1
14	PLAREVO1836-184		Wave Washer	6205	1
15	PLAREVO1216-115		Ball Bearing	6005LLU	1
16	PLAREVO1836-1119		Set Screw	1/4-20UNCx3/8"	5
17	PLAREVO1216-117		Handwheel		1
18	PLAREVO1216-118		INDEX-PIN		1
19	PLAREVO1216-119		Spring		1
20	PLAREVO1216-120		Window		1
21	PLAREVO1216-121		Spring		1
22	PLAREVO1216-122		Upper Door Shaft		1
23	PLAREVO1216-123-UK		Upper Door		1
24	PLAREVO1836-1151		Magnet		2
25	PLAREVO1836-103		Spring		1
26	PLAREVO1216-126		Spindle Lock Plunger		1

Key	Part	Number	Description	Specification	Qty
27	PLAREVO1836-132		Disc, Spindle Lock		1
28	PLAREVO1836-1141		Socket Flat Head Screw	M3x0.5x8mm	1
29	PLAREVO1836-191		C-Ring	R22	1
30	PLAREVO1216-130		Digital Readout Sensor		1
31	PLAREVO1216-131		Digital Readout		1
32	PLAREVO1216-132		Phillips Flat Head Screw	M3x0.5x5mm	4
33	PLAREVO1216-133		Control Panel		1
34	PLAREVO1216-134		Fwd/Rev Switch		1
35	PLAREVO1216-135		Socket Head Button Screw	M3x0.5x20mm	2
36	PLAREVO1216-136		Handle		2
37	PLAREVO1836-170		ON/ OFF Switch		1
38	PLAREVO1216-138		O-Ring	P22	1
39	PLAREVO1216-139		Speed Knob		1
89	PLAREVO1216-189		Strain Relief	SB5M-2	3
90	PLAREVO1216-190		Strain Relief	6P-4	3
105	PLAREVO1216-1105		O-Ring	P12	1
106	PLAREVO1216-1106		Control Box		1
110	PLAREVO1216-1110		Pan Head Self-Tapping Screw	M3x0.5x8mm	2
115	PLAREVO1216-1115-UK		Special Star Screw	M5x0.8x15mm	2
118	PLAREVO1216-1118-UK		O-Ring	P4	2



# Revo 1216 Bed, Internals, Motor

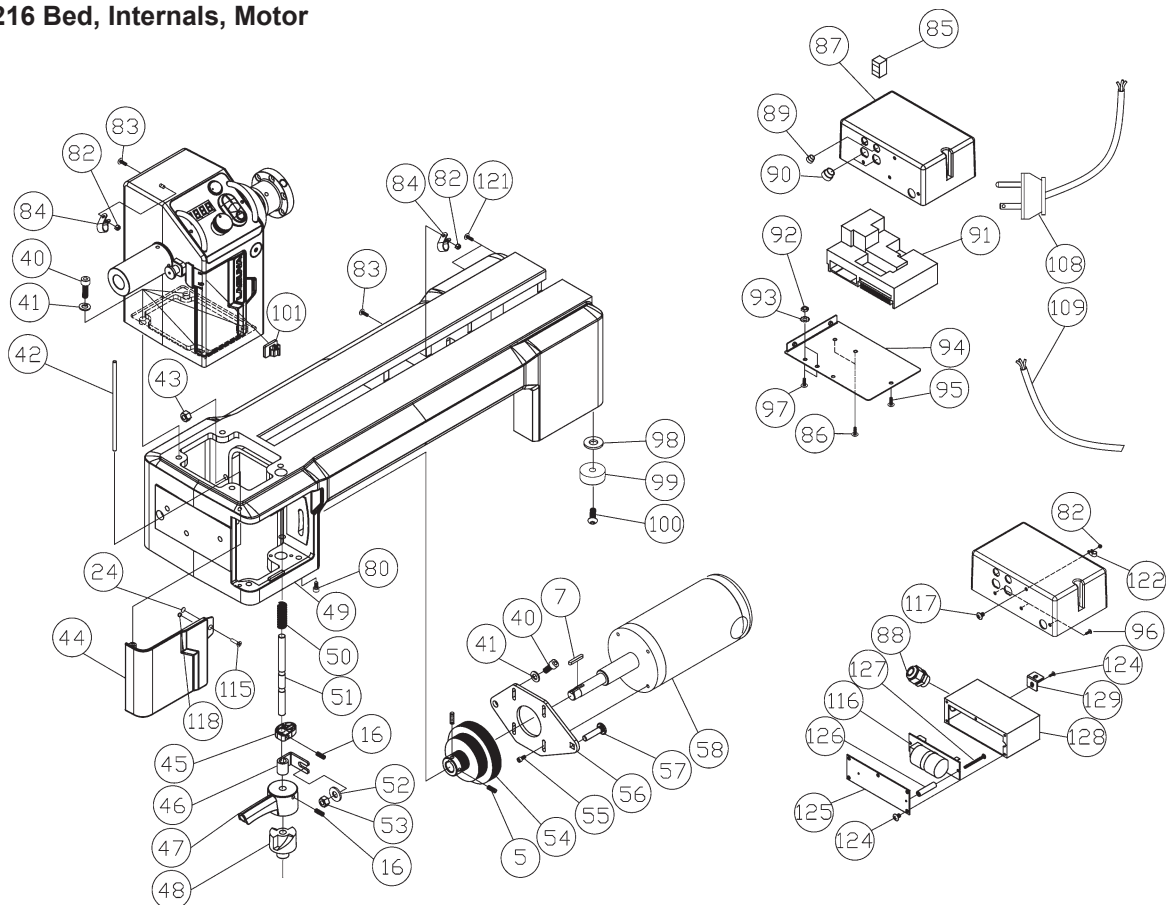

Key	Part	Number Description	Specification	Qty
5	PLAREVO1836-1101	Set Screw	1/4-20UNCx1/4"	6
7	PLAREVO1216-107	Key	5x5x25mm	2
16	PLAREVO1836-1119	Set Screw	1/4-20UNCx3/8"	5
24	PLAREVO1836-1151	Magnet		2
40	PLAREVO1216-140	Socket Head Cap Screw	3/8-16UNCx1"	5
41	PLAREVO1836-1115	Lock Washer	3/8"	5
42	PLAREVO1216-142	Lower Door Shaft		1
43	PLAREVO1216-143	Nylon Insert Lock Nut	3/8-16UNC	1
44	PLAREVO1216-144-UK	Lower Door		1
45	PLAREVO1216-145	CAM		1
46	PLAREVO1216-146	Link block		1
47	PLAREVO1216-147	Belt Tension Handle		1
48	PLAREVO1216-148	Belt Tension Base		1
49	PLAREVO1216-149-	UK Bed		1
50	PLAREVO1216-150	Spring		1
51	PLAREVO1216-151	Belt Tension Shaft		1
52	PLAREVO1836-1113	Flat Washer	D8xD18x2t	3
53	PLAREVO1216-153	Nylon Insert Lock Nut	M8x1.25	1
54	PLAREVO1216-154	Motor Pulley		1
55	PLAREVO1216-155	Socket Head Cap Screw	M5x0.8x15mm	4
56	PLAREVO1216-156	Motor Plate		1
57	PLAREVO1216-157	Carriage Bolt	M8x1.25x30mm	1
58	PLAREVO1216-158-UK	DC Motor		1
58A	PLAREVO1216-158A	Magnetic ring		1
58B	PLAREVO1216-158B	Carbon brush		2
58C	PLAREVO1216-158C	Motor Sensor		1
80	PLAREVO1216-180	Screw	M4x0.7x15mm	2
82	PLAREVO1836-1153	Hex Nut	M4x0.7	3
83	PLAREVO1216-183	Screw	M4x0.7x20mm	2
84	PLAREVO1216-184	Cord Holder		2

Key	Part	Number Description	Specification	Qty
85	71632-1115	EMI Suppression Ferrite Cores		1
86	PLAREVO1216-186	Screw	M5x0.8x15mm	2
87	PLAREVO1216-187-UK	Control Box		1
88	480BS-194	Strain Relief	PG-11	1
89	PLAREVO1216-189	Strain Relief	SB5M-2	3
90	PLAREVO1216-190	Strain Relief	6P-4	3
91	PLAREVO1216-191-UK	Control board		1
92	PLAREVO1216-192	Hex Nut	#10-32UNF 2	
93	PLAREVO1216-193	Washer, Lock-Int. Tooth	#10	2
94	PLAREVO1216-194	Cover, Base-Control Box 1		
95	PLAREVO1216-195	Pan Head Self-Tapping Screw	#8-32UNCx1/2"	2
96	PLAREVO1216-196-UK	Socket Head Button Screw	M4x0.7x6mm	3
97	PLAREVO1216-197	Screw	#10-32UNF x1/2"	2
98	PLAREVO1216-198	Flat Washer	3/8"xD27x3t	4
99	PLAREVO1216-199	Rubber Pad		4
100	PLAREVO1216-1100	Socket Head Button Screw	3/8-16UNCx1"	4
101	PLAREVO1216-1101	Cord Holder		1
108	PLAREVO1216-1108-UK	Power Cord		1
109	PLAREVO1216-1109	Control Cord		1
115	PLAREVO1216-1115-UK	Special Star Screw	M5x0.8x15mm	2
116	PLAREVO1216-1116-UK	Filter		1
117	PLAREVO1216-1117-UK	Screw	M4x0.7x10mm	1
118	PLAREVO1216-1118-UK	O-Ring	P4	2
121	PLAREVO1216-1121	Screw	M5x0.8x20mm	2
122	PLAREVO1836-1142	Cord Holder		1
124	PLAREVO1836-1152	Screw	M4x0.7x6mm	6
125	PLAREVO1216-1125-UK	Filter Box Cover		1
126	PLAREVO1216-1126-UK	Bushing		2
127	PLAREVO1216-1127-UK	Screw	M3x0.5x40mm	2
128	PLAREVO1216-1128-UK	Filter Box		1
129	PLAREVO1216-1129-UK	Filter Box Support Bracket		1

### Option: Laguna REVO 1216 Lathe Stand (ALAREVO1216-STAND)

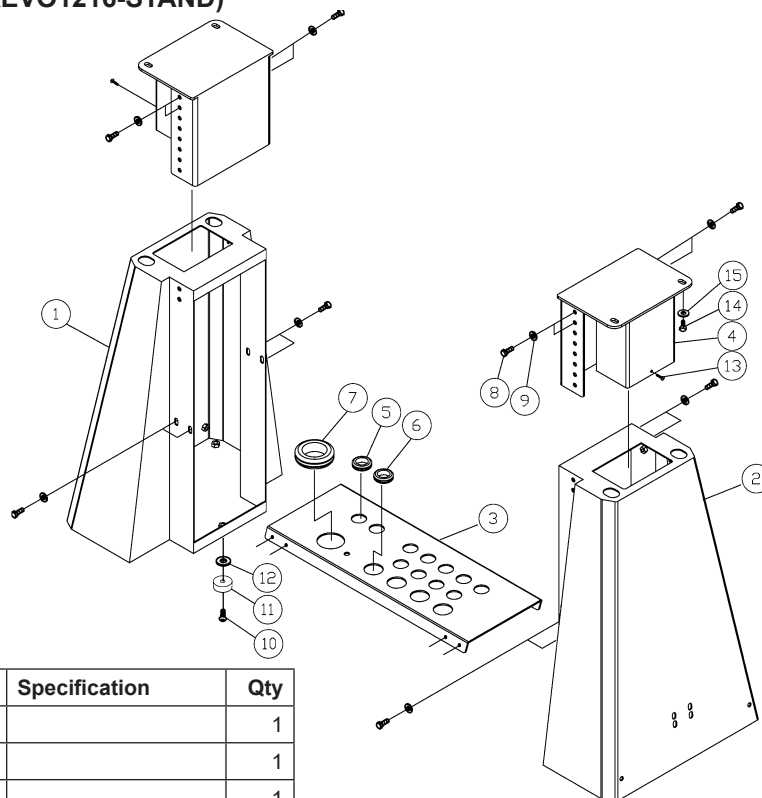

Key	Part	Number Description	Specification	Qty
1	PLAREVO1216-201	Stand		1
2	PLAREVO1216-202	Stand		1
3	PLAREVO1216-203	Connect Plate		1
4	PLAREVO1216-204	Adjust Set		2
5	PLAREVO1216-205	Rubber Bushing	D25	11
6	PLAREVO1216-206	Rubber Bushing	D35	4
7	PLAREVO1216-207	Rubber Bushing	D50	1
8	PLAREVO1216-208	Hex Cap Screw	5/16-18UNCx1/2"	16
9	PLAREVO1836-1113	Flat Washer	D8xD18x2t	16
10	PLAREVO1216-1100	Socket Head Button Screw	3/8-16UNCx1"	6
11	PLAREVO1216-199	Rubber Pad		6
12	PLAREVO1216-198	Flat Washer	3/8"xD27x3t	6
13	PLAREVO1216-213	Screw	M5x0.8x10mm	2
14	PLAREVO1216-214	Hex Cap Screw	3/8-16UNCx3/4"	4
15	PLAREVO1216-215	Flat Washer	3/8"xD23x2t	4

### Option: Laguna REVO 1216 Expansion Set (ALAREVO1216 EXTENSION)

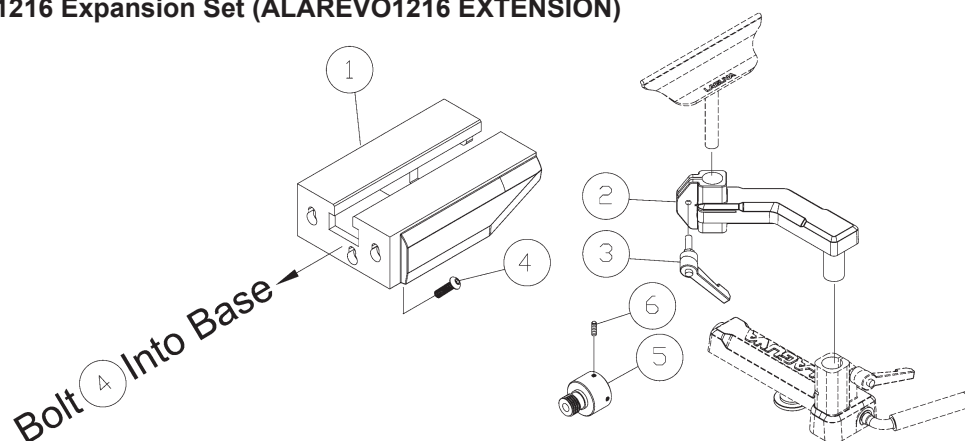

Key	Part	Number Description	Specification	Qty
1	PLAREVO1216-301	Extension Bed		1
2	PLAREVO1216-302	Toolrest Extension		1
3	PLAREVO1216-164	Lock Handle		1
4	PLAREVO1836-303	Socket Head Button Screw	3/8-16UNCx1"	3
5	PLAREVO1216-305-UK	Adapter		1
6	PLAREVO1836-1119	Set Screw	1/4-20UNCx3/8"	4

Option: Laguna REVO 1216 Mobility Kit (MBA14/12 WHEEL SYSTEM)

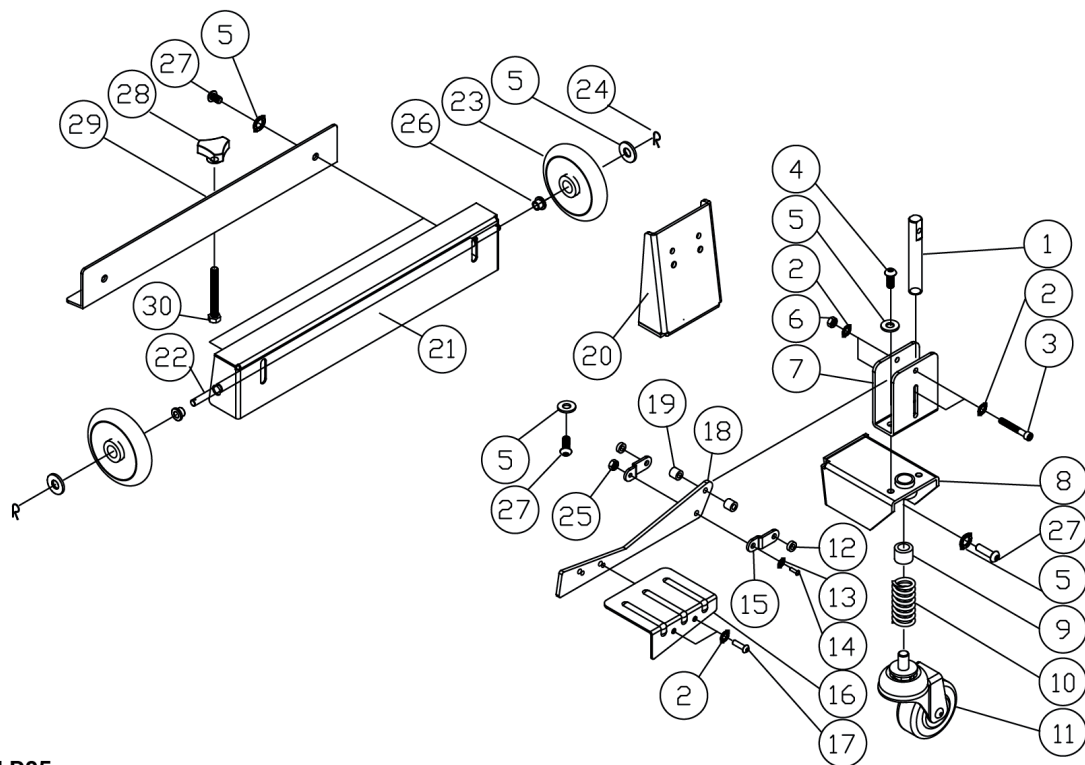

LP05

Key	Part Number	Description	Specification	Qty
1	PBAND1412-175-6-1	Rod		1
2	PBAND1412-175-6-2	Flat Washer	1/4"	6
3	PBAND1412-175-6-3	Socket Head Cap Screw	1/4-20UNCx1-3/4"	2
4	PBAND1412-175-6-4	Socket Head Button Screw	5/16-18UNCx1/2"	2
5	PBAND1412-175-6-5	Flat Washer	5/16"	11
6	PBAND1412-175-6-6	Nylon Inserted Lock Nut	1/4-20UNC	2
7	PBAND1412-175-6-7	Fixed Plate		1
8	PBAND1412-175-6-8	Wheel Bracket		1
9	PBAND1412-175-6-9	DU Bearing	MB1620DU	1
10	PBAND1412-175-6-10	Spring		1
11	PBAND1412-175-6-11	Caster		1
12	PBAND1412-175-6-12	Spacer		2
13	PBAND1412-175-6-13	Flat Washer	M5	1
14	PBAND1412-175-6-14	Screw	M5x0.8x20mm	1
15	PBAND1412-175-6-15	Connecting Plate		2
16	PBAND1412-175-6-16	Foot Pedal		1
17	PBAND1412-175-6-17	Socket Head Button Screw	1/4-20UNCx3/8"	2
18	PBAND1412-175-6-18	Plate		1
19	PBAND1412-175-6-19	Spacer		2
20	PBAND1412-175-6-20	Support Plate		1
21	PBAND1412-175-6-21	Support Plate		1
22	PBAND1412-175-6-22	Rod		1
23	PBAND1412-175-6-23	Wheel		2
24	PBAND1412-175-6-24	Retaining Pin	R8	2
25	PBAND1412-175-6-25	Nylon Inserted Lock Nut	M5x0.8	1
26	PBAND1412-175-6-26	Bushing		2
27	PBAND1412-175-6-27	Socket Head Button Screw	5/16-18UNCx3/4"	7
28	PBAND1412-175-6-28	Knob		1
29	PBAND1412-175-6-29	Support Plate		1
30	PBAND1412-175-6-30	Hex Cap Screw	M8x1.25x70mm	1